



*Valadares*

ORIGINAL BATHROOMS

---

SINCE 1921

CATÁLOGO

CATALOGO | CATALOG | CATALOGUE





**100 Anos a inovar e a trabalhar para a confiança dos clientes.**  
**A Origem:** Portugal é onde criamos, produzimos e realizamos todos os sonhos.  
**Handmade:** Adoramos a tecnologia, mas confiamos os nossos produtos ao saber e à paixão da nossa equipa.  
**Sustentabilidade:** Um desafio que enfrentamos incorporando 100% dos resíduos no processo ou garantindo 20 anos de vida para a Cerâmica.  
**Inovação:** Gresanit®, HighCer® ou HighPor® falam por nós.

**100 años innovando y trabajando para la confianza del cliente.**  
**El origen:** Portugal es donde creamos, producimos y materializamos todos los sueños.  
**Hecho a mano:** La tecnología nos apasiona pero confiamos nuestros productos a la sabiduría y pasión de nuestro equipo.  
**Sustentabilidad:** Un desafío que enfrentamos al incorporar 100% de nuestros residuos nuevamente en el proceso productivo o al garantizar 20 años de vida a toda nuestra cerámica.  
**Inovación:** Gresanit®, HighCer® or HighPor® hablan por nosotros.

**100 years innovating and working towards our client's trust.**  
**The origin:** Portugal is where we create, produce and realize all dreams.  
**Handmade:** We cherish technology but we entrust our Products to knowledge and our team's passion.  
**Sustainability:** A challenge that we face by incorporating 100% of our residues into the process or by guaranteeing 20 years life span of all our ceramics.  
**Innovation:** Gresanit®, HighCer® or HighPor® speak on our behalf.

**100 ans d'innovation et de travail pour la confiance des clients**  
**Origine:** Le Portugal est l'endroit où nous créons, produisons et réalisons tous nos rêves.  
**Fabriqué à la main:** Nous aimons la technologie, mais nous confions nos produits aux connaissances et à la passion de notre équipe.  
**Durabilité:** Un défi auquel nous sommes confrontés en réutilisant 100% des déchets dans le processus ou en garantissant 20 ans de vie à la céramique.  
**Innovation:** Gresanit®, HighCer® ou HighPor® parlent pour nous.



ADVANCED RESEARCH CERAMIC HERITAGE

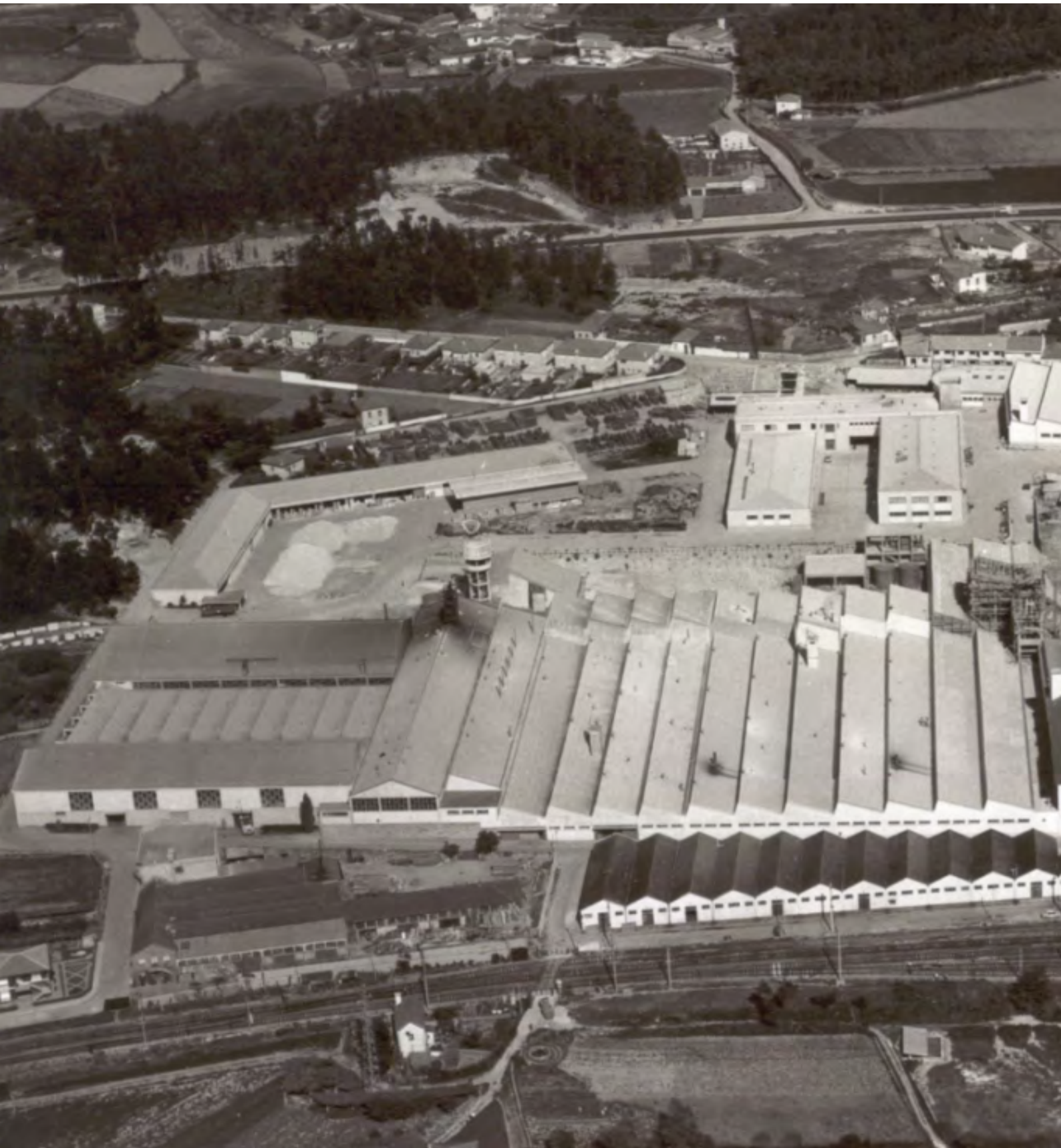



# marca centenária

centenary brand | marca centenaria | marque centenaire

# cores

color • color • couleur



-  **00 BRANCO**  
BLANCO | WHITE | BLANC
-  **07 AZUL YORK**  
AZUL YORK | BLUE YORK | BLEU YORK
-  **12 AZUL PASTEL**  
AZUL PASTEL | BLUE PASTEL | BLEU PASTEL
-  **13 ROSA IMPERIAL**  
ROSA IMPERIAL | IMPERIAL ROSE | ROSE IMPÉRIALE
-  **15 CAPPUCCINO**
-  **18 AMARELO SAARA**  
AMARILLO SAARA | YELLOW SAARA | JAUNE SAARA
-  **20 PERGAMON**
-  **21 AZUL CAPRI**  
AZUL CAPRI | BLUE CAPRI | BLEU CAPRI
-  **23 BRANCO ÁRTICO**  
BLANCO ÁRTICO | WHITE ARTIC | BLANC ARTIC
-  **27 VERDE AMAZÓNIA**  
VERDE AMAZÓNIA | AMAZON GREEN | VERTE AMAZON
-  **28 VERDE JADE**  
JADE VERDE | JADE GREEN | VERT JADE
-  **33 CEREJA**  
CEREZA | CHERRY | CERISE
-  **37 CINZA BASALTO**  
GRIS BASALTO | GREY BASALT | GRIS BASALTE
-  **38 CINZA BRUMA**  
GRIS NIEBLA | MIST GRAY | GRIS BROULLIARD
-  **41 ROSA QUARTZO**  
ROSA CUARTZO | QUARTZ PINK | ROSE QUARTZ
-  **44 PETRÓLEO**  
PETRÓLEO | PETROLEUM | PÉTROLE
-  **46 MARFIM**  
MARFIL | IVORY | IVOIRE
-  **47 ARDÓSIA**  
PIZARRA | SLATE | ARDOISE
-  **48 PRETO**  
NEGRO | BLACK | NOIR
-  **50 CACAU**  
CACCAU | COCCOA | CACAO

# simbologia

simbologia · symbology



#### Descarga eficaz c/ 2,5L/ 4L

Descarga efectiva c/ 2,5L/ 4L  
Effective discharge w/ 2,5L/ 4L  
Décharge efficace av/ 2,5L/ 4L



#### Descarga eficaz c/ 3L/ 5L

Descarga efectiva c/ 3L/ 5L  
Effective discharge w/ 3L/ 5L  
Décharge efficace av/ 3L/ 5L



#### Estruturas de bacia suspensa com 10 anos de garantia

Estructuras para inodoro suspendido con 10 años de garantía  
Conceled systems for wall - hung WC with 10 year warranty  
Bâti-supports avec garantie de 10 ans



#### Bacia c/ comprimento 60cm

Inodoro con longitud 60cm  
WC length 60cm  
Toilette avec longueur de 60cm



#### Resistência ao escorregamento

Resistencia a la resbaladad  
Resistance slip  
Résistance au glissement



#### Artigos cerâmico com 20 anos de garantia

Artículos cerámicos con 20 años de garantía  
Ceramic articles with 20 years warranty  
Articles céramiques avec garantie de 20 ans



#### Torneiras com 5 anos de garantia

Grifos con 5 años de garantía  
Taps with 5 years warranty  
Robinets avec garantie de 5 ans



#### Tampo soft-close

Tapa soft-close  
Soft-close toilet seat  
Abattant soft-close



#### Certificação hídrica do autoclismo

Certificación hidrica  
Hydric certification toilet  
Certification hydrique



# GRESANIT®





Oceanus	Junior	Infantil	PMR	Urinois Urinaris Urinoirs	Lavatórios Pousar Sobre mueble Standing À poser	Lavatórios Especiais Speciales specials Spéciaux	Outros Lavatórios Otros Lavabos Other Washbasins Autres Lavabos	Bases de Chuveiro Platos de ducha Shower trays Receveurs de douche	Peças técnicas Piezas técnicas Technical pieces Pièces te- chniques	Acessórios Accesorios Accessories Accessoires	Torneiras Luna Grifo luna Tap luna Robinet Luna	Placa Estrutura Structure plate Plaque de Structure
X	X	X	X	X	X	X	X	X	X	X	X	X
					X							
					X							
					X							
					X							
X												
					X							
					X	X					X	X
					X							
					X							
					X							
					X							
					X	X						
					X							
X	X			X	X	X	X	X			X	X
					X							
								X				
					X			X			X	X

# Valadares

ORIGINAL BATHROOMS

SINCE 1921



Indice  
Index



---

## SÉRIES SANITÁRIAS

SERIES SANITARIAS  
SANITARY WARE COLLECTIONS  
SÉRIES SANITAIRES

**P. 13**

---

## PEÇAS TÉCNICAS

PIEZAS TÉCNICAS  
TECHNICAL PIECES  
PIÈCES TECHNIQUES

**P. 123**

---

## LAVATÓRIOS

LAVABOS  
WASHBASINS  
LAVABOS

**P. 127**

---

## MÓVEIS

MUEBLES  
FURNITURE  
MEUBLES

**P. 171**

---

## BASES DE CHUVEIRO

PLATOS DE DUCHA  
SHOWER TRAYS  
RECEVEURS DE DOUCHE

**P. 185**

---

## RESGUARDOS

MAMPARAS  
SHOWER CABINS  
PANNEAUX DOUCHE

**P. 197**

---

## BANHEIRAS

BAÑERAS  
BATHTUBS  
BAIGNOIRES

**P. 205**

---

## TORNEIRAS

GRIFERIA  
TAPS  
ROBINETS

**P. 215**

---

## ACESSÓRIOS CERÂMICOS

ACCESORIOS CERÁMICA  
CERAMIC ACCESSORIES  
ACCESOIRES CÉRAMIQUES

**P. 245**

---

SÉRIES SANITÁRIAS



SERIES SANITARIAS



SANITARY WARE COLLECTIONS



SÉRIES SANITAIRES





# Egg

COMPACTA | COMPACTA | CLOSE COUPLED | COMPACTE



### A ORIGEM DA PERFEIÇÃO

Uma série de linhas voluptuosas, desenhada pela arquiteta de interiores Gracinha Viterbo. Absolutamente perfeita.

### EL ORIGEN DE LA PERFECCIÓN

Una serie de líneas voluptuosas, diseñado por la arquitecta de interiores Gracinha Viterbo. Absolutamente perfecto.

### THE ORIGIN OF PERFECTION

A series of voluptuous lines, designed by interior designer Gracinha Viterbo. Absolutely perfect.

### L'ORIGINE DE LA PERFECTION

Une série de lignes voluptueuses, conçue par l'architecte d'intérieur Gracinha Viterbo. Absolument parfait.



5



7







- 
- 1 **39357002C** (50x38x12 cm)
  - 2 **39881002C** (48x52x90 cm)
  - 3 **39071002V** (50x40x40 cm)  
**39071002H** (50x40x40 cm)

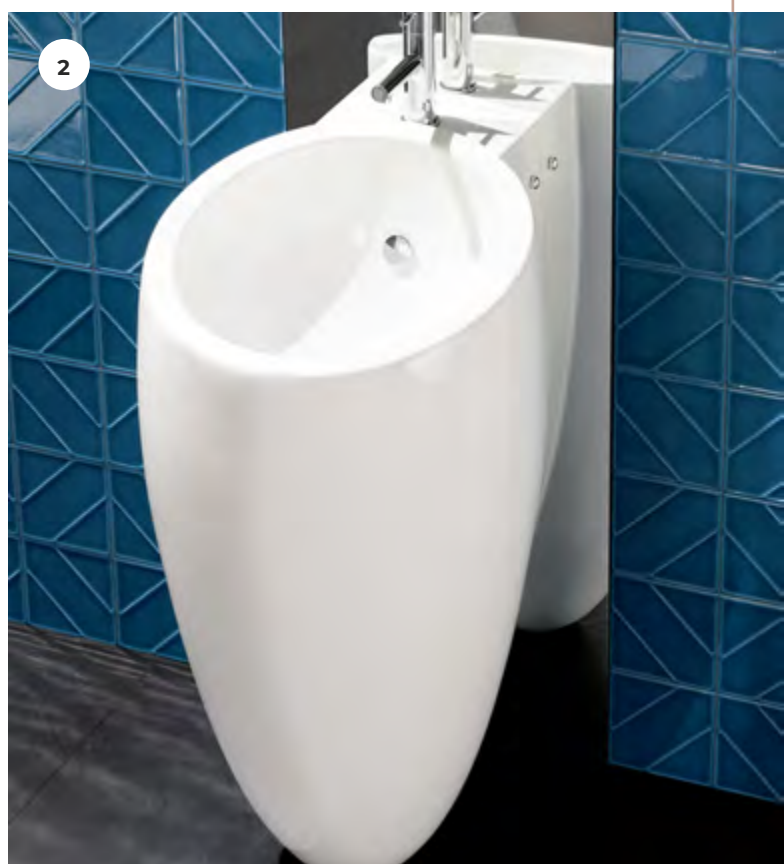

- 
- 4 **39142002K** (39x14x91 cm)  
**50564011**
  - 5 **39071002K** (50x40x40 cm)  
**39071002W** (50x40x40 cm)
  - 6 **50264005**
  - 7 **39411002K** (50x40x40 cm)

# Egg

SUSPENSIVA | SUSPENDIDA | WALL HUNG | SUSPENDUE



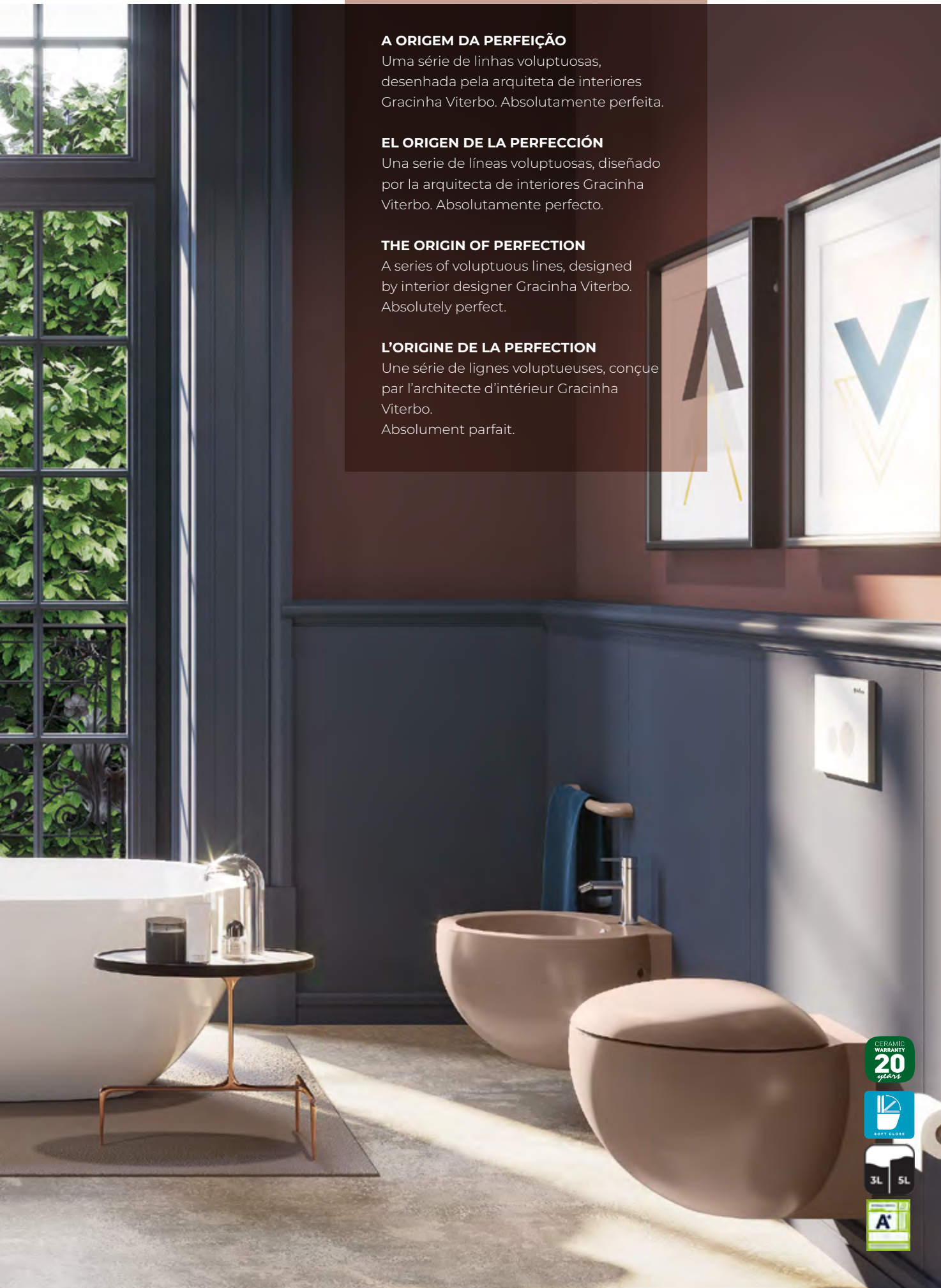

#### A ORIGEM DA PERFEIÇÃO

Uma série de linhas voluptuosas, desenhada pela arquiteta de interiores Gracinha Viterbo. Absolutamente perfeita.

#### EL ORIGEN DE LA PERFECCIÓN

Una serie de líneas voluptuosas, diseñado por la arquitecta de interiores Gracinha Viterbo. Absolutamente perfecto.

#### THE ORIGIN OF PERFECTION

A series of voluptuous lines, designed by interior designer Gracinha Viterbo. Absolutely perfect.

#### L'ORIGINE DE LA PERFECTION

Une série de lignes voluptueuses, conçue par l'architecte d'intérieur Gracinha Viterbo. Absolument parfait.

CERAMIC  
WARRANTY  
**20**  
years

SOFT CLOSE

3L 5L

A





---

1 39871002K (35x34x59 cm)

2 50615322

3 39001002K (50x40x33 cm)

4 50268005

5 39401002K (50x40x33 cm)



# Nautilus

COMPACTA | COMPACTA | CLOSE COUPLED | COMPACTE



### A ORIGEM INSPIRADORA

Nautilus, animal ancestral, testemunha do início da vida na Terra e objecto de admiração pela precisão da sua espiral perfeita.

### EL ORIGEN INSPIRADORA

Nautilus, animal antiguo, testigo del comienzo de la vida en la Tierra y objeto de admiración por la exactitud de su espiral perfecta.

### THE INSPIRING ORIGIN

Nautilus, ancient animal, witness of the beginning of life on Earth and object of admiration for the precision of its perfect spiral.

### L'ORIGINE INSPIRANT

Nautilus, ancien animal, témoin du début de la vie sur Terre et objet de l'admiration pour la précision de sa spirale parfaite.









- 
- 1 **34351002C** (51x51x14 cm)
  - 2 **34331002C** (51x51x20 cm)
  - 3 **34200002K** (28x21x65 cm)
  - 4 **34554002V** (60x38x40 cm)  
**34554002H** (60x38x40 cm)

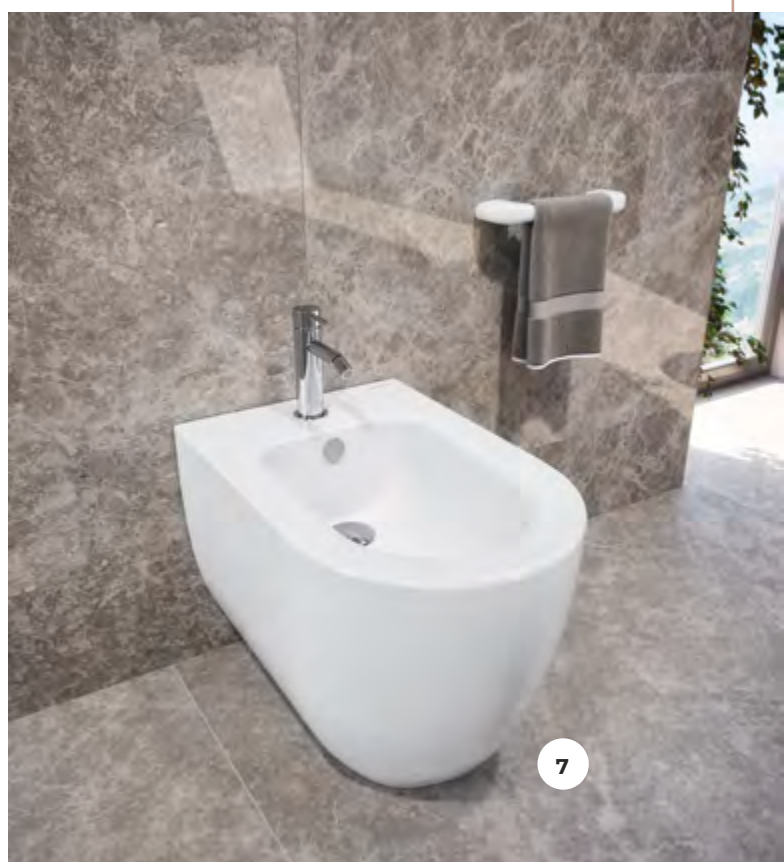

- 
- 5 **50212000**
  - 6 **34192002K** (38x15x47 cm)  
**50592042**
  - 7 **34414002K** (56x37x40 cm)

# Nautilus

SUSPENSIVA | SUSPENDIDA | WALL HUNG | SUSPENDUE



### A ORIGEM INSPIRADORA

Nautilus, animal ancestral, testemunha do início da vida na Terra e objecto de admiração pela precisão da sua espiral perfeita.

### EL ORIGEN INSPIRADORA

Nautilus, animal antiguo, testigo del comienzo de la vida en la Tierra y objeto de admiración por la exactitud de su espiral perfecta.

### THE INSPIRING ORIGIN

Nautilus, ancient animal, witness of the beginning of life on Earth and object of admiration for the precision of its perfect spiral.

### L'ORIGINE INSPIRANT

Nautilus, ancien animal, témoin du début de la vie sur Terre et objet de l'admiration pour la précision de sa spirale parfaite.





---

1 34331002C (51x51x20 cm)

2 34220002K (28x32x25 cm)

3 34004002K (52x37x36 cm)  
34504002K (52x37x36 cm)

4 50239000

5 34404002K (52x37x32 cm)



# one

COMPACTA | COMPACTA | CLOSE COUPLED | COMPACTE



### UM SONHO MATERIALIZADO

ONE celebra o primeiro ano da ARCH Valadares. Robusta e graciosa. Especial e Inspiradora.

### UN SUEÑO MATERIALIZADO

ONE celebra el primer año de ARCH Valadares. Robusto y elegante. Especial e inspiradora.

### A DREAM MATERIALIZED

ONE celebrates the first year of ARCH Valadares. Robust and graceful. Special and inspirational.

### UN RÊVE MATÉRIALISÉ

ONE célèbre la première année de ARCH Valadares. Robuste et gracieuse. Spéciale et une source d'inspiration.

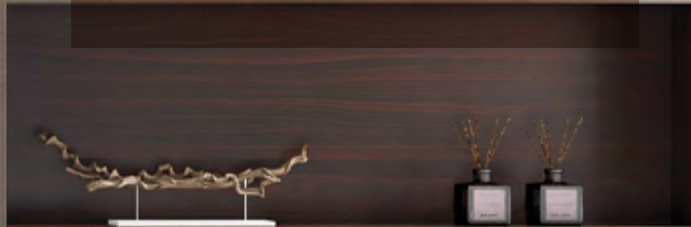







- 
- 1 **40331002C** (120x45x12 cm)  
**40321002C** (100x45x12 cm)  
**40311002C** (80x45x12 cm)  
**40301002C** (60x45x12 cm)
  - 2 **55174140** 120  
**55174130** 100  
**55174080** 80  
**55174070** 60
  - 3 **40051002V** (60x38x40 cm)  
**40051002H** (60x38x40 cm)



- 
- 4 **40182002K** (38x15x41 cm)  
**50542031**
  - 5 **50202000**
  - 6 **40411002K** (50x36x40 cm)

# one

SUSPENSA | SUSPENDIDA | WALL HUNG | SUSPENDUE



### UM SONHO MATERIALIZADO

ONE celebra o primeiro ano da ARCH Valadares. Robusta e graciosa. Especial e Inspiradora.

### UN SUEÑO MATERIALIZADO

ONE celebra el primer año de ARCH Valadares. Robusto y elegante. Especial e inspiradora.

### A DREAM MATERIALIZED

ONE celebrates the first year of ARCH Valadares. Robust and graceful. Special and inspirational.

### UN RÊVE MATÉRIALISÉ

ONE célèbre la première année de ARCH Valadares. Robuste et gracieuse. Spéciale et une source d'inspiration.



CERAMIC  
WARRANTY  
**20**  
years







---

1 40350002C (51x39x13 cm)

2 40357002C (47x35x13 cm)

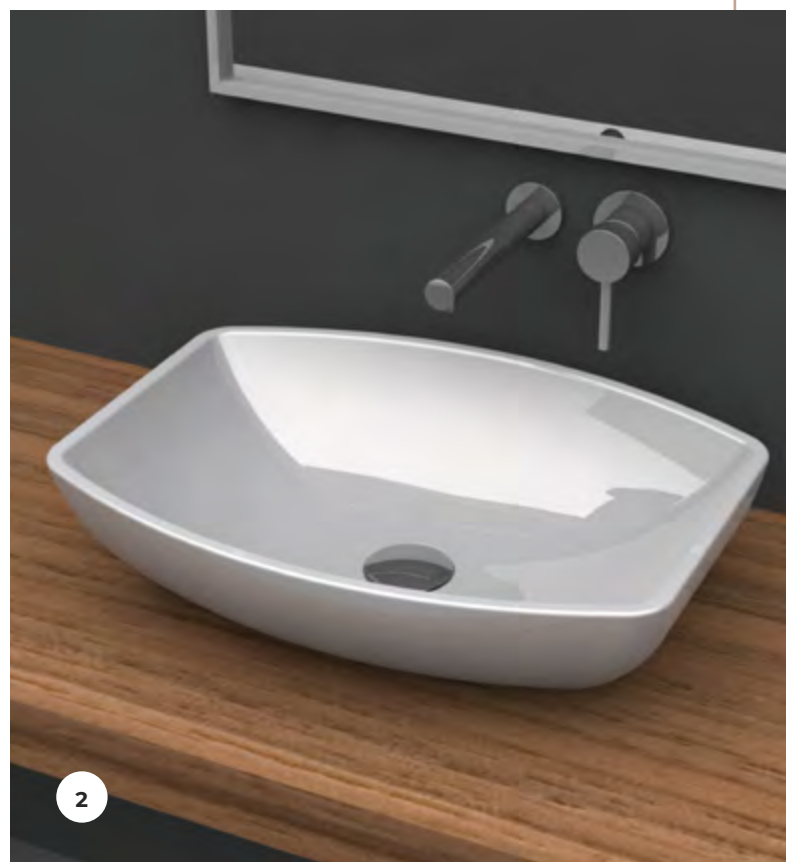

---

3 40001002K (50x38x36 cm)

4 50202000

5 40401002K (50x38x30 cm)

# TWO

COMPACTA | COMPACTA | CLOSE COUPLED | COMPACTE



**LEVE E SUBTIL**

A coleção TWO revela como as formas simples podem ser criativas e inovadoras.

**LIGERO Y SUTIL.**

La colección TWO revela cómo las formas simples pueden ser creativas e innovadoras.

**LIGHT AND SUBTLE.**

The TWO collection reveals how simple shapes can be creative and innovative.

**LÉGÈRE ET SUBTILE**

La collection TWO révèle à quel point les formes simples peuvent être créatives et innovantes.









- 
- 1 **79910002C** (diâm. 45x82 cm)  
**79911002C** (diâm. 45x82 cm)
  - 2 **41051002V** (60x38x41 cm)  
**41051002H** (60x38x41 cm)
  - 3 **41182002K** (38x13x43 cm)  
**55519020**



- 
- 4 **50204000**
  - 5 **41411002K** (50x37x41 cm)

# TWO

BTW RIMLESS



**LEVE E SUBTIL**

A coleção TWO revela como as formas simples podem ser criativas e inovadoras.

**LIGERO Y SUTIL.**

La colección TWO revela cómo las formas simples pueden ser creativas e innovadoras.

**LIGHT AND SUBTLE.**

The TWO collection reveals how simple shapes can be creative and innovative.

**LÉGÈRE ET SUBTILE**

La collection TWO révèle à quel point les formes simples peuvent être créatives et innovantes.







1 79920002C (diâm. 44x21 cm)

2 70240002 (100x50x2 cm)  
70140002 (80x50x2 cm)  
70040002 (60x50x2 cm)

3 55181001

4 41541002V (50x37x41 cm)  
41541002H (50x37x41 cm)

5 50204000

6 41411002K (50x37x41 cm)



# TWO

SUSPENSIVA | SUSPENDIDA | WALL HUNG | SUSPENDUE



**LEVE E SUBTIL**

A coleção TWO revela como as formas simples podem ser criativas e inovadoras.

**LIGERO Y SUTIL.**

La colección TWO revela cómo las formas simples pueden ser creativas e innovadoras.

**LIGHT AND SUBTLE.**

The TWO collection reveals how simple shapes can be creative and innovative.

**LÉGÈRE ET SUBTILE**

La collection TWO révèle à quel point les formes simples peuvent être créatives et innovantes.









1 79920002C (diâm. 44x21cm)

2 41001002K (50x37x30 cm)

3 41501002K (50x37x30 cm)

4 50204000

5 41401002K (50X37X30 cm)



# Light

SUSPENSA | SUSPENDIDA | WALL HUNG | SUSPENDUE



#### A REINTERPRETAÇÃO DA LEVEZA

Design urbano, minimalista, numa série leve, harmoniosa e carregada de personalidade.

#### LA REINTERPRETACIÓN DE LA LIGEREZA

Diseño minimalista y urbano, en una serie ligera, armoniosa y llena de personalidad.

#### THE REINTERPRETATION OF LIGHTNESS

Urban and minimalist design in a light, harmonious and full of personality series.

#### LA RÉINTERPRÉTATION DE LÉGÈRETÉ

Design urbain et minimaliste, une série légère, harmonieuse et pleine de personnalité.



SUSPENSA | SUSPENDIDA | WALL HUNG | SUSPENDUE

1





---

1 **36331982** (55x45x18 cm)

2 **36001982K** (56x39x33 cm)



---

3 **50243000**

4 **36401982K** (56x39x23 cm)

# Neoclássica

COMPACTA | COMPACTA | CLOSE COUPLED | COMPACTE





**O PERFEITO EQUILIBRIO**

A intemporalidade do clássico. Revivalista mas elegante, com a personalidade de um objecto de culto.

**EL EQUILIBRIO PERFECTO**

La intemporalidad del clásico. Revivalista pero elegante, con la personalidad de un objeto de culto.

**THE PERFECT BALANCE**

The timelessness of the classic. Revivalist but elegant, with the personality of a cult object.

**L'ÉQUILIBRE PARFAIT**

L'intemporalité du classique. Revivalist mais élégant, avec la personnalité d'un objet de culte









- 
- 1 **16321002C** (67x50x23 cm)  
**16331002C** (61x50x23 cm)
  - 2 **16200002K** (26x26x65 cm)
  - 3 **16024002K** (67x38x40 cm)  
**16021002K** (67x38x40 cm)
  - 4 **16163002K** (50x18x37 cm)  
**16161002K** (50x18x37 cm)  
**55503001**  
**55503002**



- 
- 5 **50376000**
  - 6 **16411002K** (60x35x38 cm)

# Neoclàssica

NORMAL



### O PERFEITO EQUILIBRIO

A intemporalidade do clássico. Revivalista mas elegante, com a personalidade de um objecto de culto.

### EL EQUILIBRIO PERFECTO

La intemporalidad del clásico. Revivalista pero elegante, con la personalidad de un objeto de culto.

### THE PERFECT BALANCE

The timelessness of the classic. Revivalist but elegant, with the personality of a cult object.

### L'ÉQUILIBRE PARFAIT

L'intemporalité du classique. Revivalist mais élégant, avec la personnalité d'un objet de culte



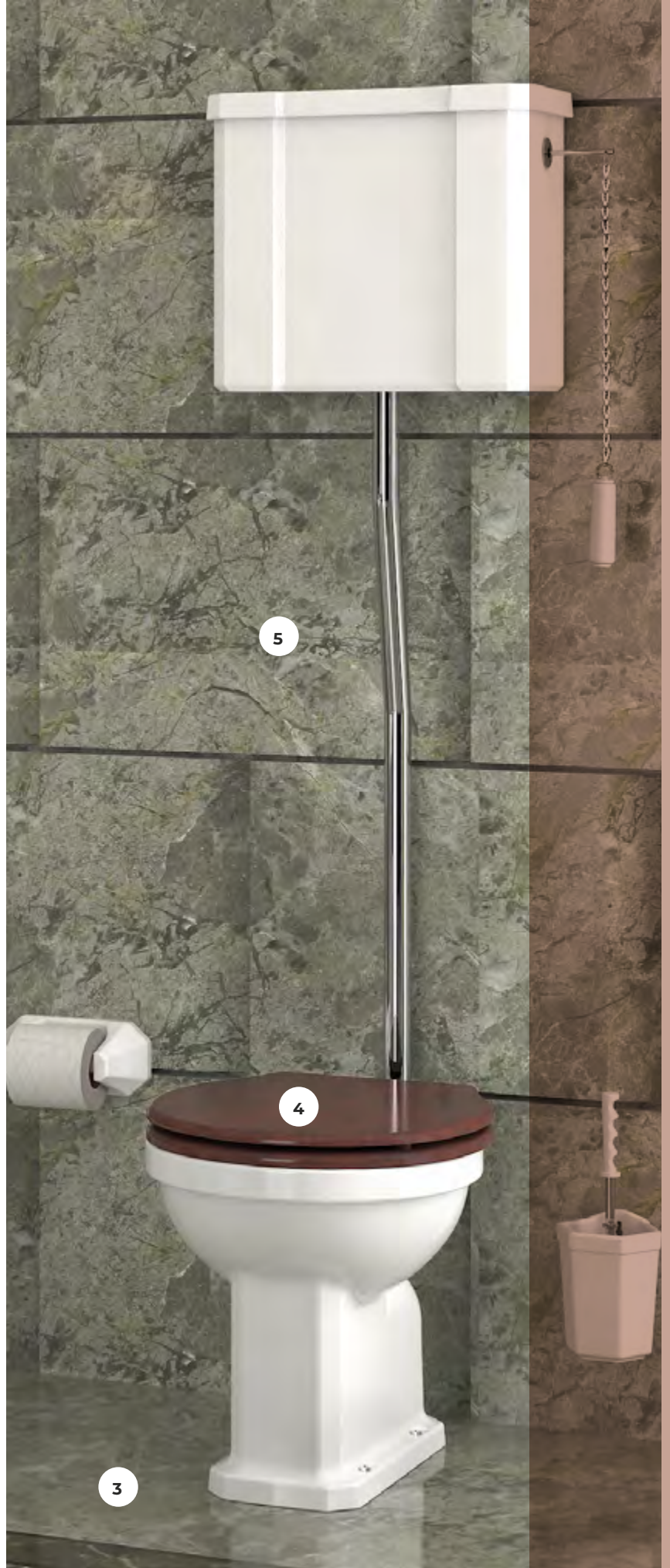



- 
- 1 **16351002C** (61x50x27 cm)
  - 2 **16200002K** (26x26x65 cm)
  - 3 **16011002K** (46x38x38 cm)  
**16014002K** (46x38x38 cm)



- 
- 4 **50377000**
  - 5 **16131002K** (50x18x37 cm)  
**50591001**
  - 6 **16411002K** (60x35x38 cm)
  - 7 **51100002** (175x80x72 cm)  
**51100001** (167x75x65 cm)

# Neoclássica

BTW



### O PERFEITO EQUILIBRIO

A intemporalidade do clássico. Revivalista mas elegante, com a personalidade de um objecto de culto.

### EL EQUILIBRIO PERFECTO

La intemporalidad del clásico. Revivalista pero elegante, con la personalidad de un objeto de culto.

### THE PERFECT BALANCE

The timelessness of the classic. Revivalist but elegant, with the personality of a cult object.

### L'ÉQUILIBRE PARFAIT

L'intemporalité du classique. Revivalist mais élégant, avec la personnalité d'un objet de culte









- 
- 1 **78331002C** (120x50x25 cm)  
**78321002C** (100x55x25 cm)  
**78311002C** (80x55x25 cm)
  - 2 **50700042** (120 cm)  
**50700032** (100 cm)  
**50700022** (80 cm)
  - 3 **16041002K** (50x37x40 cm)



- 
- 4 **55038002**
  - 5 **50376000**
  - 6 **16441002K** (50x37x40 cm)

# Neoclásica

SUSPENSA | SUSPENDIDA | WALL HUNG | SUSPENDUE



### O PERFEITO EQUILIBRIO

A intemporalidade do clássico. Revivalista mas elegante, com a personalidade de um objecto de culto.

### EL EQUILIBRIO PERFECTO

La intemporalidad del clásico. Revivalista pero elegante, con la personalidad de un objeto de culto.

### THE PERFECT BALANCE

The timelessness of the classic. Revivalist but elegant, with the personality of a cult object.

### L'ÉQUILIBRE PARFAIT

L'intemporalité du classique. Revivalist mais élégant, avec la personnalité d'un objet de culte



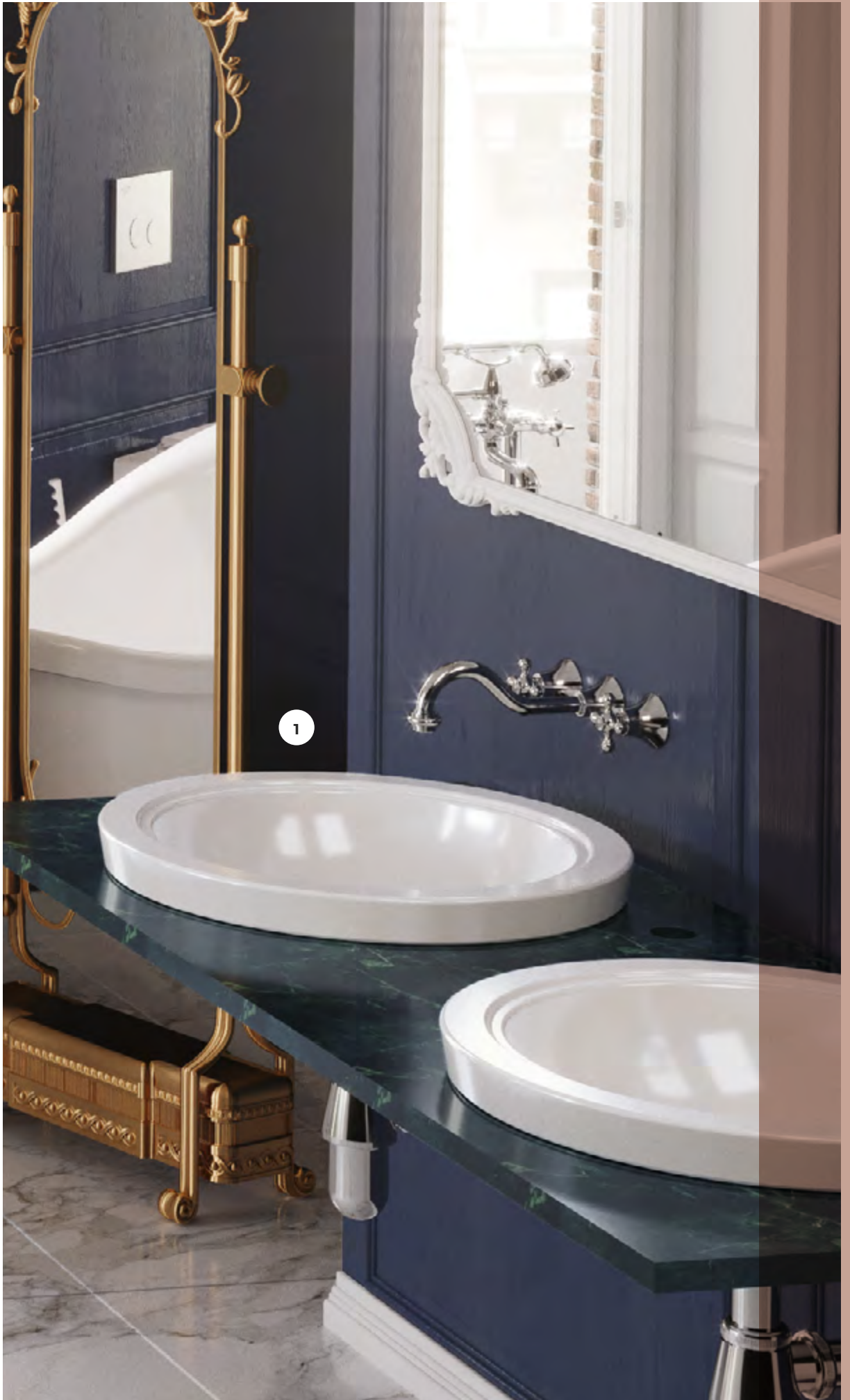



1 16387002C (diâm. 45x15 cm)

2 16001002K (50x37x30 cm)

3 50376000

4 16401002K (50x37x30 cm)

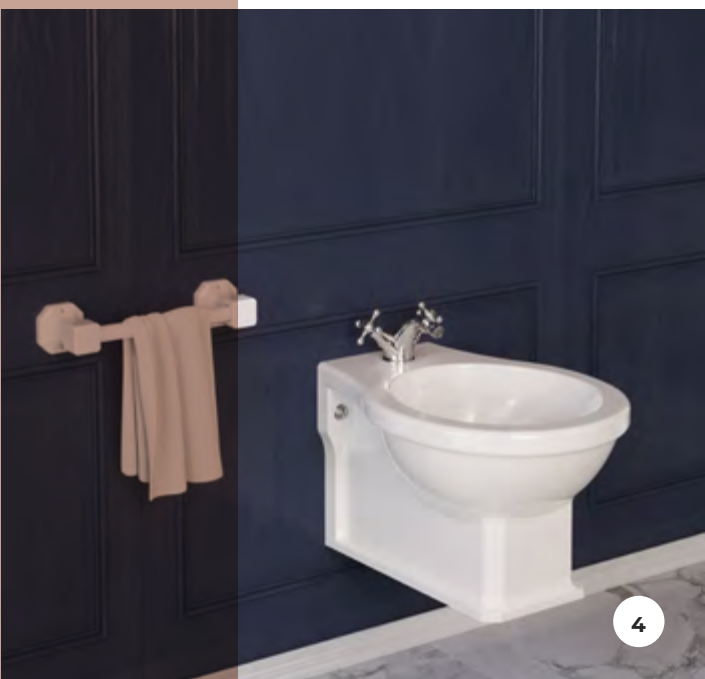

100

COMPACTA | COMPACTA | COMPACTA | CLOSE COUPLED | COMPACTE



A inovação e o caráter que comemoram um Centenário.

Innovación y diseño que celebran un Centenario.

Innovation and character that celebrates a Centenary.

Innovation et caractère qui célèbrent un centenaire.



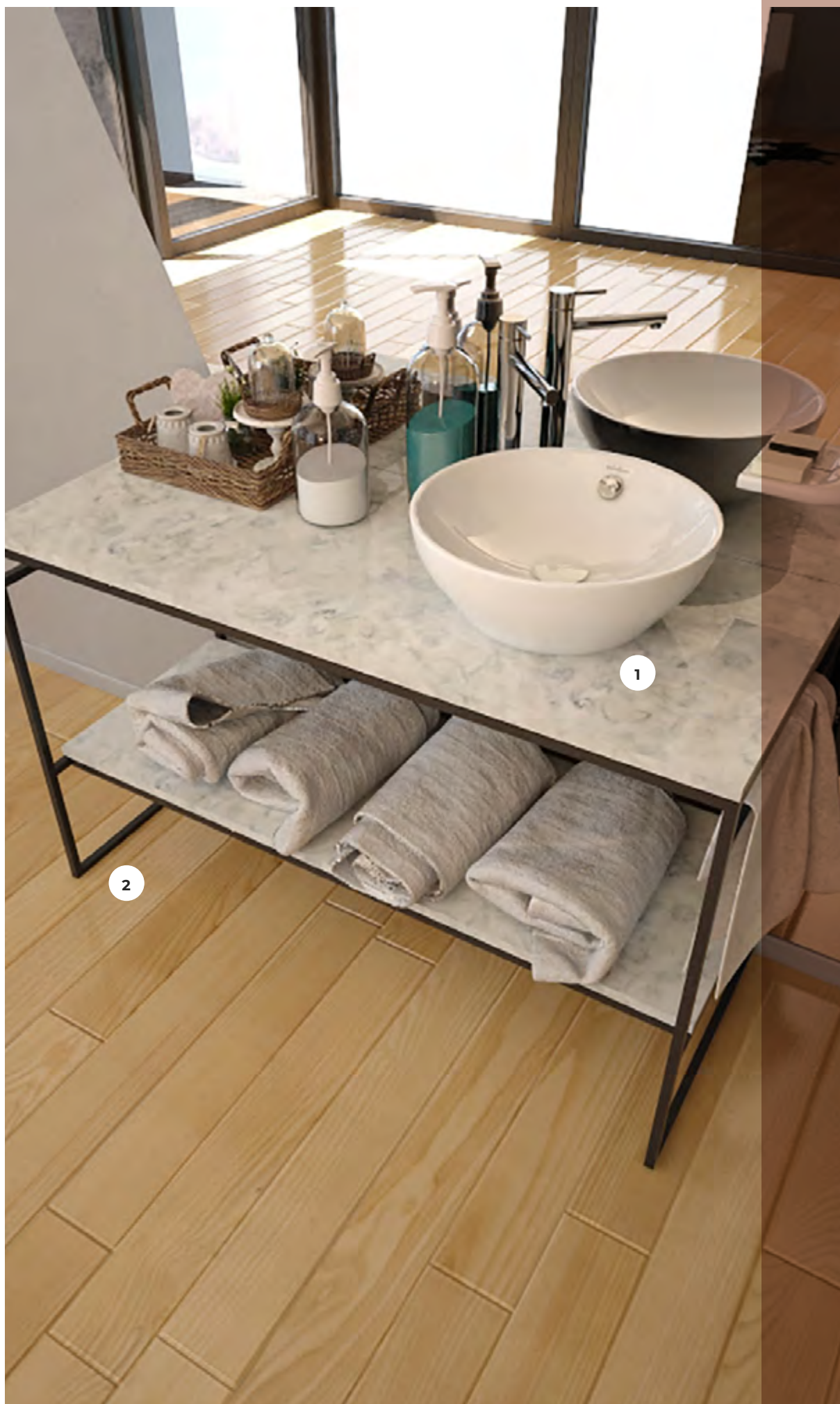





- 
- 1 42350002C (diâm. 40x14 cm)
  - 2 52892123 (120x50x80 cm)
  - 3 42551002V (60x37x41 cm)  
42551002H (60x37x41 cm)



- 
- 4 42182002K (37x14x41 cm)  
55519032
  - 5 50210000
  - 6 42411002K (50x37x41 cm)

# 100

SUSPENSIVA | SUSPENDIDA | WALL HUNG | SUSPENDUE

TODAY  
IS A  
GOOD  
DAY  
TO HAVE  
A GOOD  
DAY



A inovação e o caráter que comemoram um Centenário.

Innovación y diseño que celebran un Centenario.

Innovation and character that celebrates a Centenary.

Innovation et caractère qui célèbrent un centenaire.

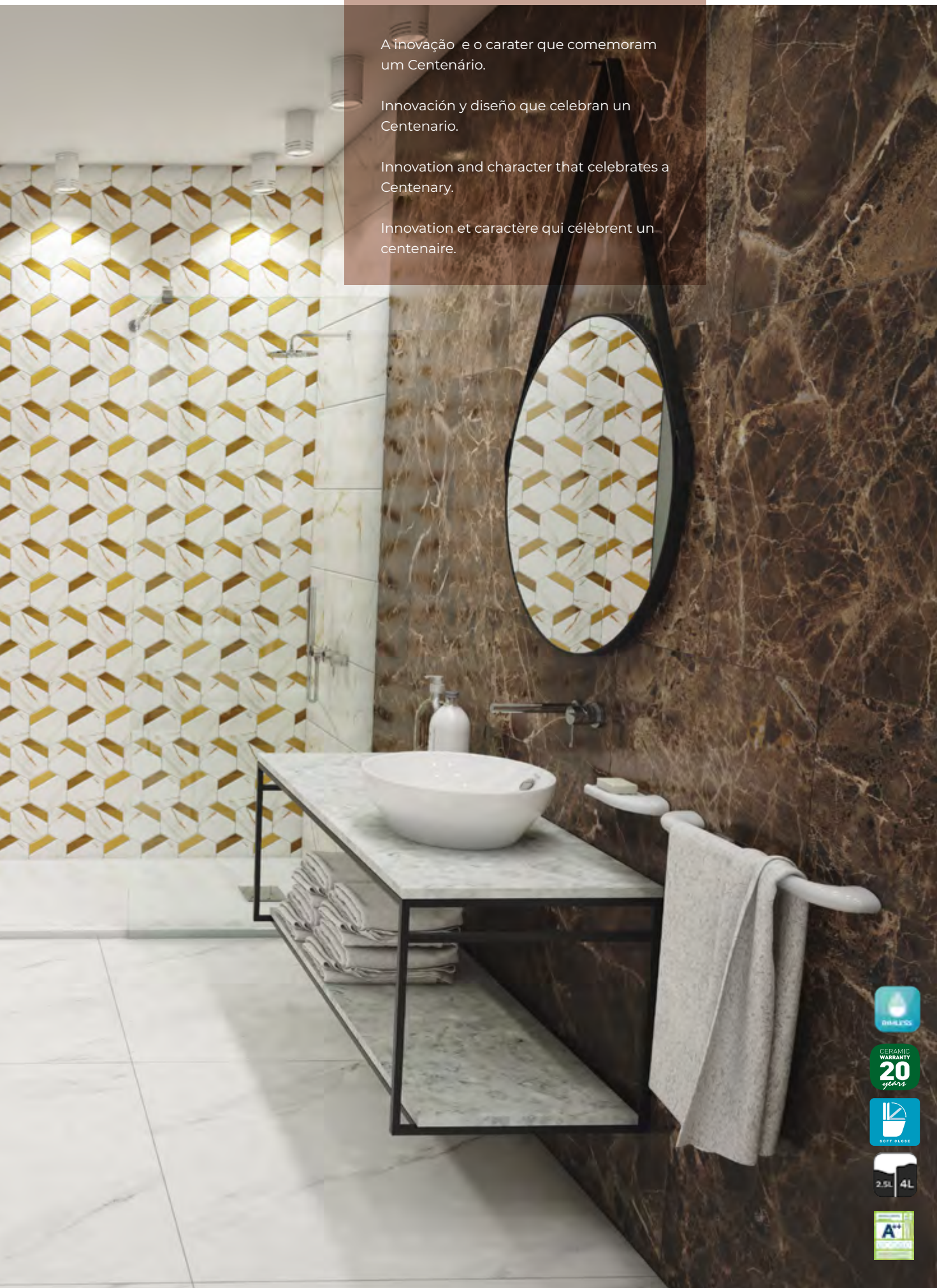





---

1 42350002C (diâm. 40x14 cm)

2 52882123 (120x50x50 cm)

3 42501002K (50x37x33 cm)

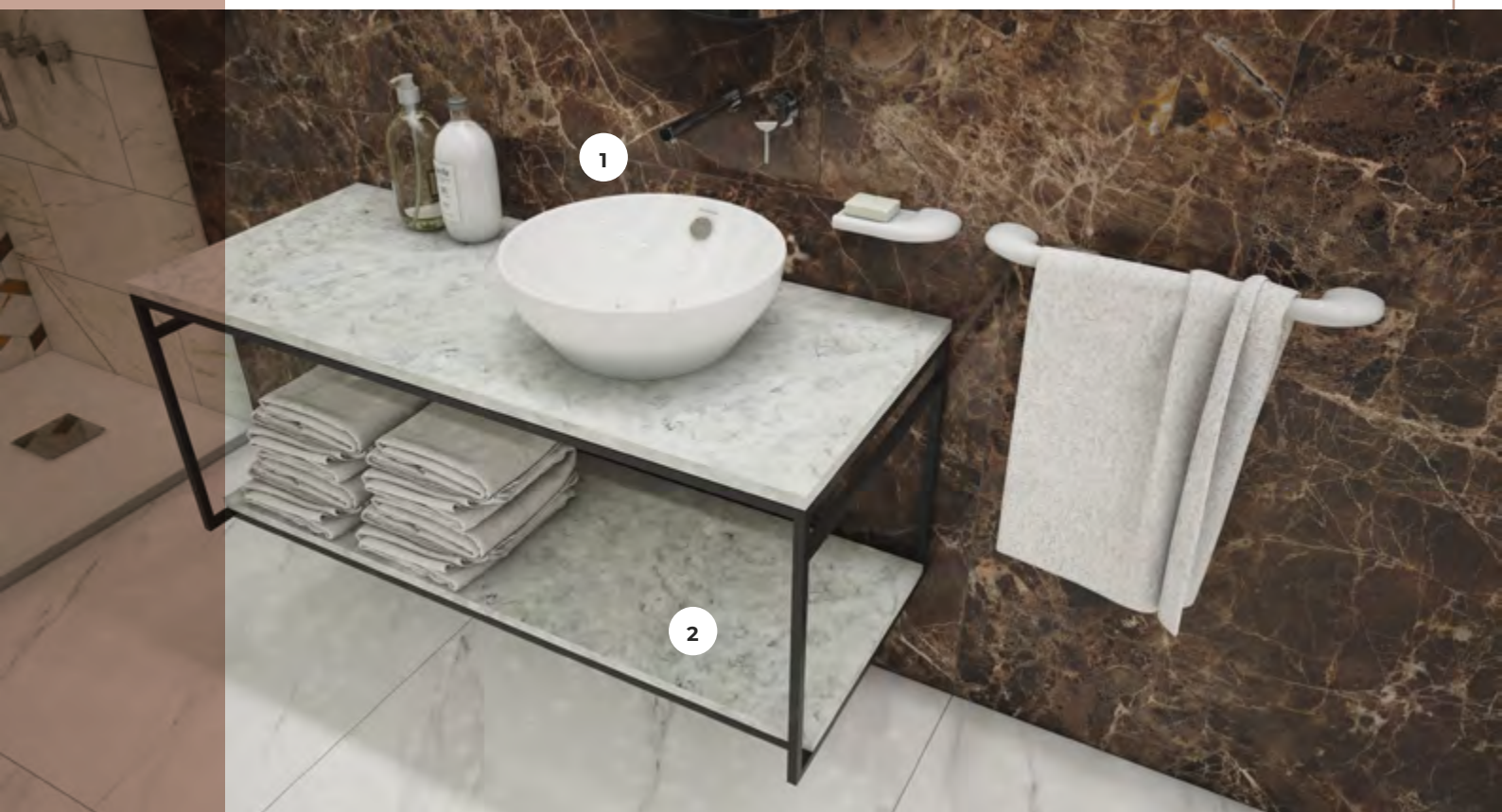

1

2

---

4 50210000

5 42401002K (50x37x33 cm)

**Z**

COMPACTA | COMPACTA | CLOSE COUPLED | COMPACTE



### **SIMPLESMENTE ÚNICA**

As obras fazem-se assim. De linhas curvas e simples, esta é uma colecção inspiradora.

### **SIMPLEMENTE ÚNICA**

Las obras se hacen así. De líneas curvas y simples, esto es una colección inspiradora.

### **SIMPLY ONLY**

Artworks are done like this. With curved and simple lines, this is an inspiring collection.

### **SIMPLEMENT UNIQUE**

Les œuvres sont faits comme ça. Des lignes courbes et simples, cela est une collection inspirante.



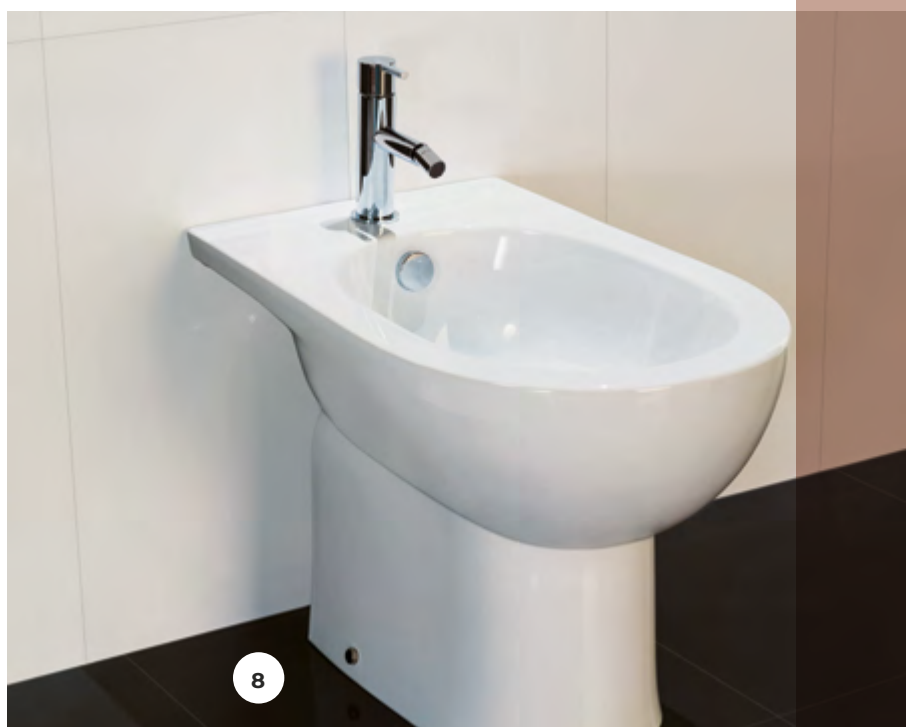





- 
- 1** **37331002C** (61x50x19 cm)  
**37311002C** (56x45x18 cm)
  - 2** **37200002K** (18x17x70 cm)
  - 3** **37051002V** (60x35x40 cm)  
**37051002H** (60x35x40 cm)
  - 4** **37182002K** (34x15x40 cm)  
**37181002K** (34x15x40 cm)  
**55519010**  
**55517101**



- 
- 5** **37071002V** (53x35x40 cm)  
**37071002H** (53x35x40 cm)
  - 6** **50208000**
  - 7** **37441002K** (55x36x41 cm)
  - 8** **37411002K** (55x36x41 cm)



# Opus

SUSPENSA | SUSPENDIDA | WALL HUNG | SUSPENDUE



### SIMPLESMENTE ÚNICA

As obras fazem-se assim. De linhas curvas e simples, esta é uma colecção inspiradora.

### SIMPLESMENTE ÚNICA

Las obras se hacen así. De líneas curvas y simples, esto es una colección inspiradora.

### SIMPLY ONLY

Artworks are done like this. With curved and simple lines, this is an inspiring collection.

### SIMPLEMENT UNIQUE

Les œuvres sont faits comme ça. Des lignes courbes et simples, cela est une collection inspirante.







- 
- 1 **37331002C** (61x50x19 cm)  
**37311002C** (56x45x18 cm)
  - 2 **37220002K** (22x27x32 cm)
  - 3 **37001002K** (50x35x36 cm)



- 
- 4 **50208000**
  - 5 **37401002K** (50x36x28 cm)

# Oceanus

COMPACTA | COMPACTA | CLOSE COUPLED | COMPACTE



### **MERGULHO NO HORIZONTE**

Inspirada no mar e no movimento das ondas que o vento contempla. A Harmonia e versatilidade de uma coleção especial.

### **BUCEO EN EL HORIZONTE**

Inspirado por el mar y por el movimiento de las olas contempladas por el viento. La armonía y la versatilidad de una colección especial.

### **DIVING ON THE HORIZON**

Inspired by the sea and by the movement of waves contemplated by the wind. The Harmony and versatility of a special collection.

### **PLONGÉE À L'HORIZON**

Inspiré par le mouvement de la mer et des vagues envisagées par le vent. L'harmonie et la polyvalence d'une collection spéciale.









- 
- 1 **13321002C** (68x49x21 cm)  
**13331002C** (61x47x21 cm)  
**13311002C** (55x43x21 cm)
  - 2 **37200002K** (18x17x70 cm)
  - 3 **13023002K** (69x37x40 cm)
  - 4 **13182002K** (34x20x34 cm)  
**13181002K** (34x20x34 cm)  
**55517021**  
**55517041**
  - 5 **50340000**

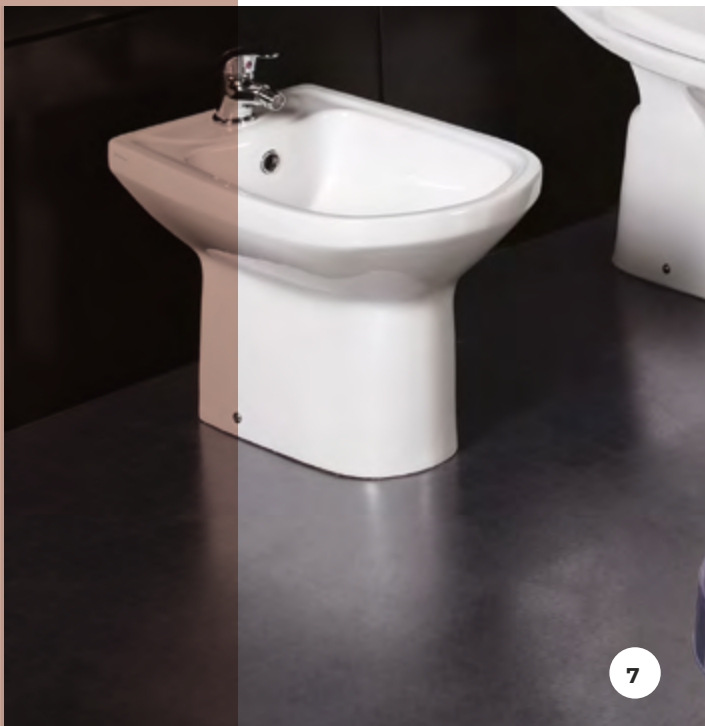

- 
- 6 **13013002K** (57x37x40 cm)
  - 7 **13411002K** (56x37x40 cm)

# Oceanus

SUSPENSA | SUSPENDIDA | WALL HUNG | SUSPENDUE



### **MERGULHO NO HORIZONTE**

Inspirada no mar e no movimento das ondas que o vento contempla. A Harmonia e versatilidade de uma coleção especial.

### **BUCEO EN EL HORIZONTE**

Inspirado por el mar y por el movimiento de las olas contempladas por el viento. La armonía y la versatilidad de una colección especial.

### **DIVING ON THE HORIZON**

Inspired by the sea and by the movement of waves contemplated by the wind. The Harmony and versatility of a special collection.

### **PLONGÉE À L'HORIZON**

Inspiré par le mouvement de la mer et des vagues envisagées par le vent. L'harmonie et la polyvalence d'une collection spéciale.







1 **13321002C** (68x49x21 cm)

**13331002C** (61x47x21 cm)

**13311002C** (55x43x21 cm)

2 **37220002K** (22x27x32 cm)

3 **13001002K** (53x37x38 cm)

4 **50340000**

5 **13401002K** (54x37x37 cm)





# estruturas para sanitário suspense

estructuras para sanitários suspendidos  
concealed systems for wall-hung WC  
bâti-chasses

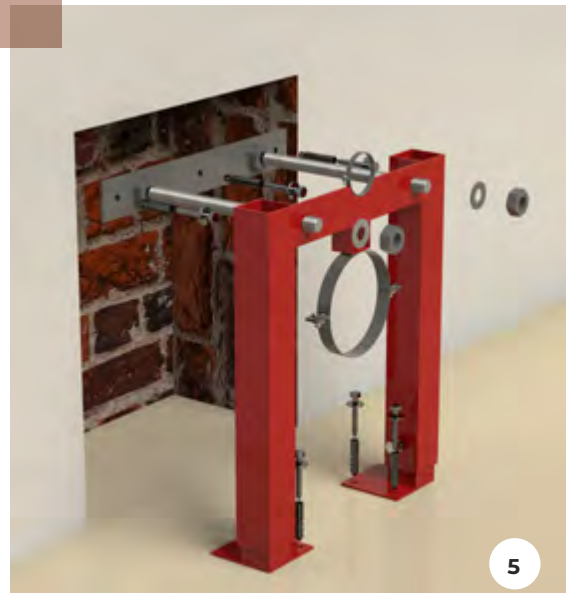
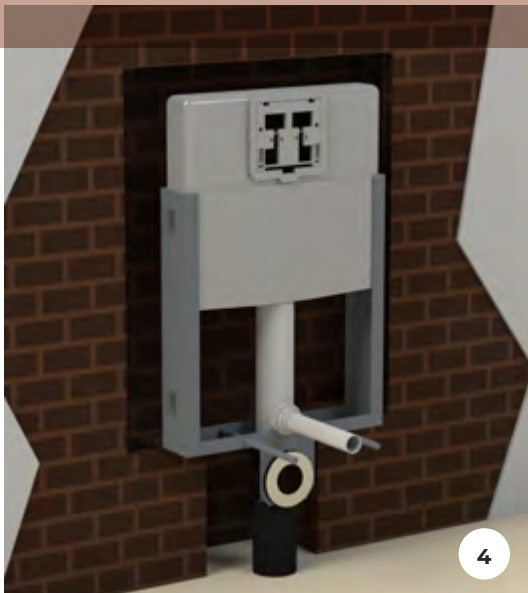

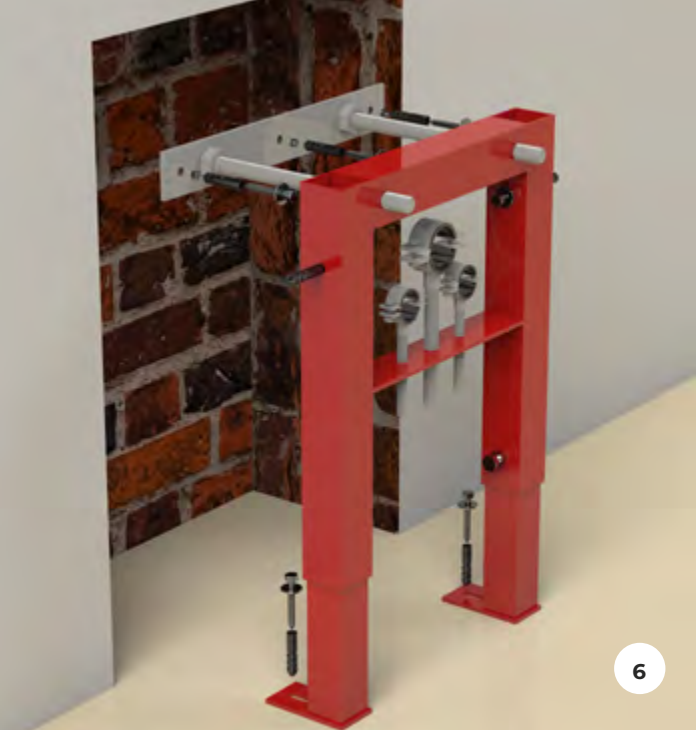

1 55037074

2 55037076

3 55037075

4 55037094

5 55036201

6 55046001

7 50603010

8 55035001

9 55038002

10 55034305

11 55034201  
55034211

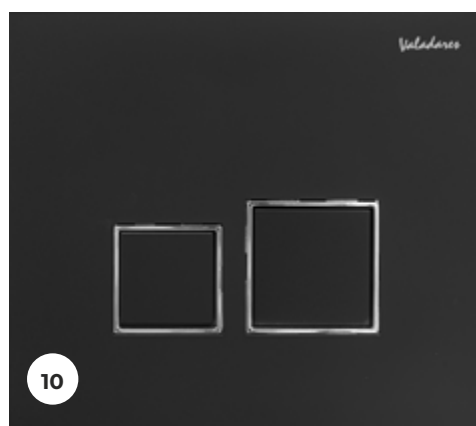

# Júnior





**O ENCANTO DA CRIATIVIDADE UM  
SORRISO A CADA MOMENTO**

De formas curvas e um toque de cor, esta é uma coleção divertida, criada à medida das crianças.

**EL ENCANTO DE LA CREATIVIDAD UNA  
SONRISA A CADA MOMENTO**

De formas curvas y un toque de color, esta es una divertida colección, creada para los niños.

**THE CHARM OF CREATIVITY A SMILE  
EVERY MOMENT**

With curved shapes and a touch of colour, this is a fun collection, created for children.

**LE CHARM DE LA CRÉATIVITÉ UN  
SOURIRE TOUS LE TEMPS**

De formes courbes et une touche de couleur, ceci est une collection amusante, créée pour les enfants.







- 
- 1 18601002C (38x36x61 cm)
  - 2 18651002KV (39x28x29 cm)  
18651002KH (39x28x29 cm)
  - 3 18651002KS (39x28x29 cm)
  - 4 50259520



# Infantil



### À MEDIDA DA IMAGINAÇÃO

As linhas clássicas e distintas remetem-nos para a escola antiga. Uma série Handmade que alia a funcionalidade à alegria da cor.

### À LA MEDIDA DE LA IMAGINACIÓN

Las líneas clásicas y distintas nos llevan a la vieja escuela. Una serie hecha a mano que combina la funcionalidad con la alegría del color.

### TO THE EXTENT OF THE IMAGINATION

The classic and distinct lines brings us to the old school. A handmade series combining the functionality with the joy of colour.

### A LA MESURE DE L'IMAGINATION

Les lignes classiques et distinctes nous amènent à la vieille école. Une série Handmade combinant la fonctionnalité à la joie de la couleur.



CERAMIC  
WARRANTY  
**20**  
years





---

1 16371002C (40x32x20 cm)

2 16230002K (19x19x49 cm)

3 18650002K (35x27x29 cm)

4 50308530

**PMR**







**MÁXIMA ACESSIBILIDADE  
DISTINTAMENTE INCLUSIVA**

A coleção PMR tem como prioridade a acessibilidade, aliando-a à estética. De linhas simples e modernas, mais do que inclusiva, a facilidade de utilização é um compromisso garantido.

**MÁXIMA ACCESIBILIDAD  
DISTINTAMENTE INCLUSIVA**

La colección PMR prioriza la accesibilidad, combinada a la estética. Con unas líneas simples y modernas, más que inclusiva, la facilidad de uso es un compromiso asegurado.

**MAXIMUM ACCESSIBILITY DISTINCTLY  
INCLUSIVE**

The PMR collection prioritizes accessibility combined to aesthetics. With simple and modern lines, more than inclusive, the facility of use is an assured engagement.

**ACCESSIBILITÉ MAXIMALE  
DISTINCTEMENT INCLUSIVE**

La collection PMR privilégie l'accessibilité, la combinant à l'esthétique. Avec des lignes simples et modernes, plus qu'inclusive, la facilité d'utilisation est un engagement assurée.







1 **78781002C** (62x55x20 cm)

2 **78791002C** (67x57x24 cm)

3 **55025000**

4 **18003002K** (52x36x37 cm)

5 **50261000**

6 **18063002K** (56x36x45 cm)

7 **50221000**

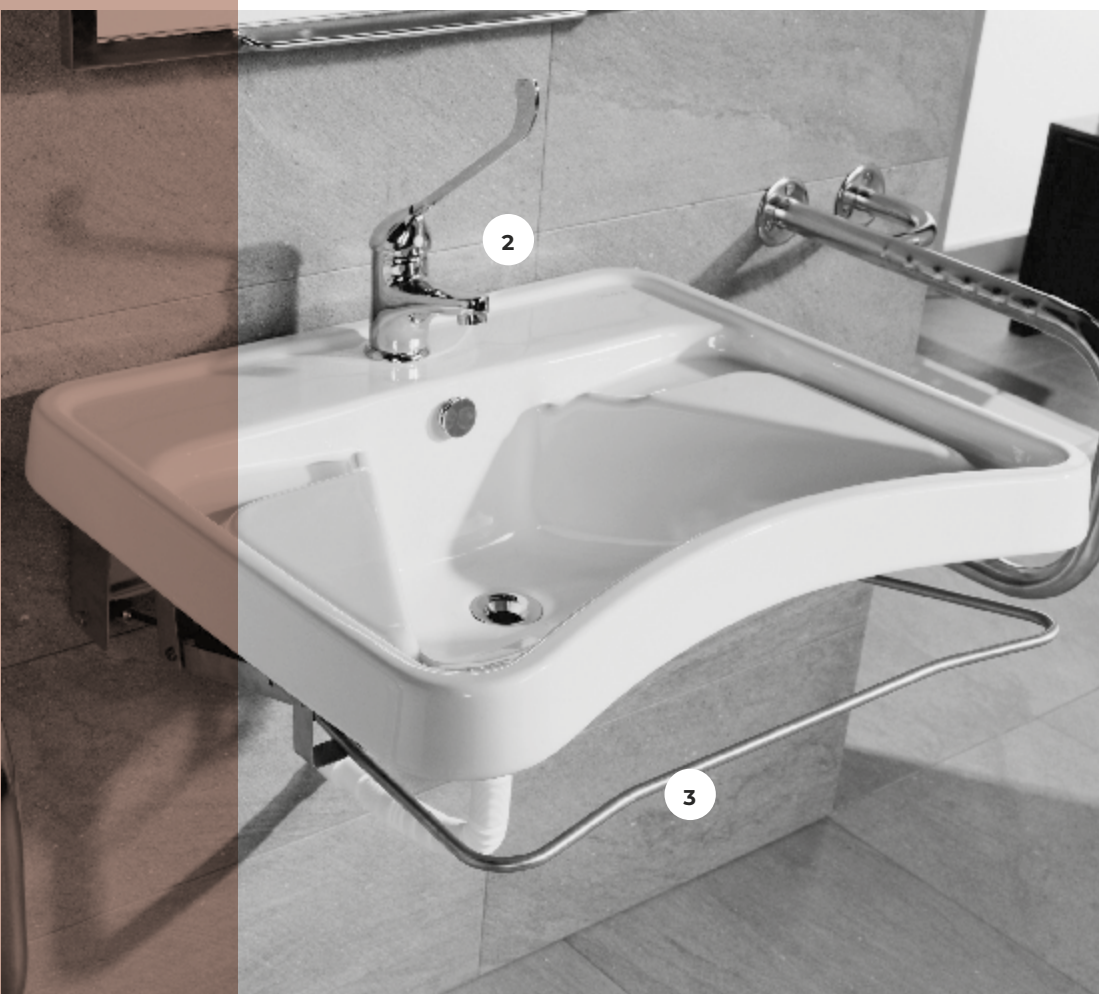



9





---

8 33141002 (39x19x36 cm)  
55510041

9 55517091

10 78639002 (90x90x6 cm)

11 50989010  
50989020

11

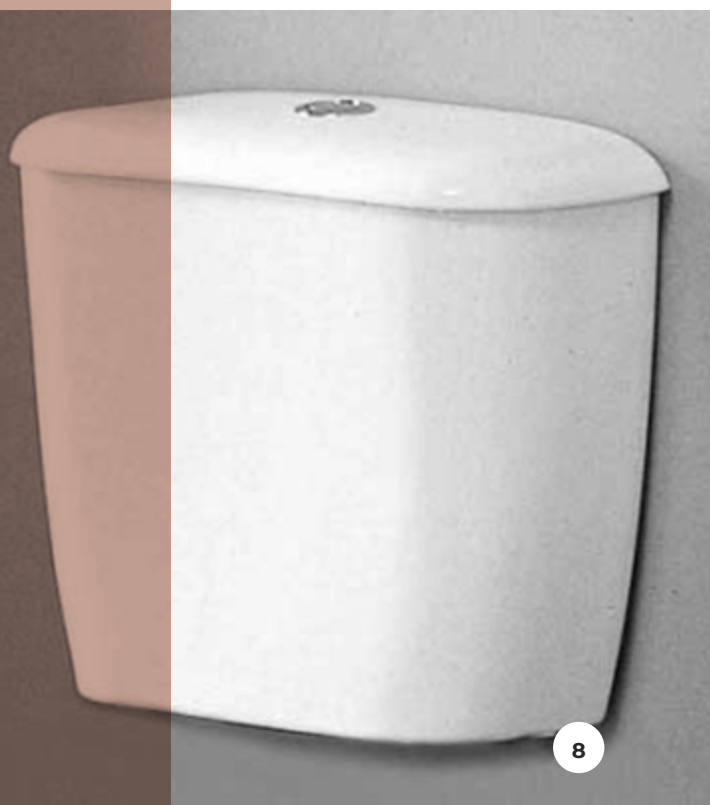

8

# PMR

torneiras | griferia | taps | robinets



1



5



2



4



3



6

1 50682012

2 50667132

3 50663022

4 50663032

5 50663042

6 50663000

7 50680012

8 50680022



7



8

# PMR

acessórios | accesorios | accessories | accessoires



9



12



10



13



11



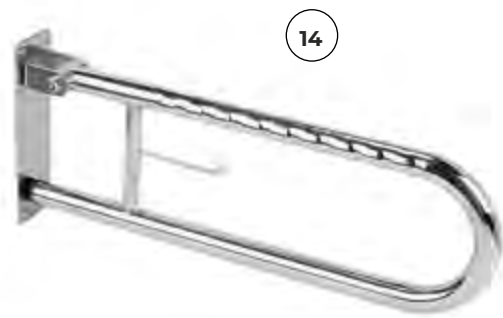

14

9 55140060  
55140170

10 55059010

11 55140090  
55140100

12 55140020  
55140030

13 55140120  
5514013

14 55140140

15 55140300

16 55140110

17 55140070  
55140080

18 55140040 40 cm  
55140050 50 cm  
55140010 60 cm



15



17



16



18

# Urinóis

URINARIOS | URINALS | URINOIRS



**FORMAS INTELIGENTES  
FUNCIONALIDADE EM PRIMEIRO  
LUGAR**

Uma gama completa de urinóis com compromisso com a funcionalidade, o conforto e adaptabilidade a diferentes necessidades arquitectónicas.

**FORMAS INTELIGENTES  
FUNCIONALIDAD EN PRIMER LUGAR**

Una gama completa de urinarios con compromiso de funcionalidad, confort y adaptabilidad a las diferentes necesidades arquitectónicas.

**INTELLIGENT FORMS FUNCTIONALITY  
FIRST**

A full range of urinals with commitment to functionality, comfort and adaptability to different architectural needs.

**FORMES INTELLIGENTS  
FONCTIONNALITÉ EN PREMIÈRE**

Une gamme complète d'urinoirs avec engagement à la fonctionnalité, le confort et la capacité d'adaptation aux différents besoins architecturaux.





---

1 **78560002K** (42x25x75 cm)

2 **39530002K** (34x31x66 cm)

3 **78530002K** (39x26x57 cm)







4 18511002K (49x27x70 cm)

5 18550002K (33x31x41 cm)

6 18541002k (32x25x42 cm)

7 78924002K (35x6x70 cm)



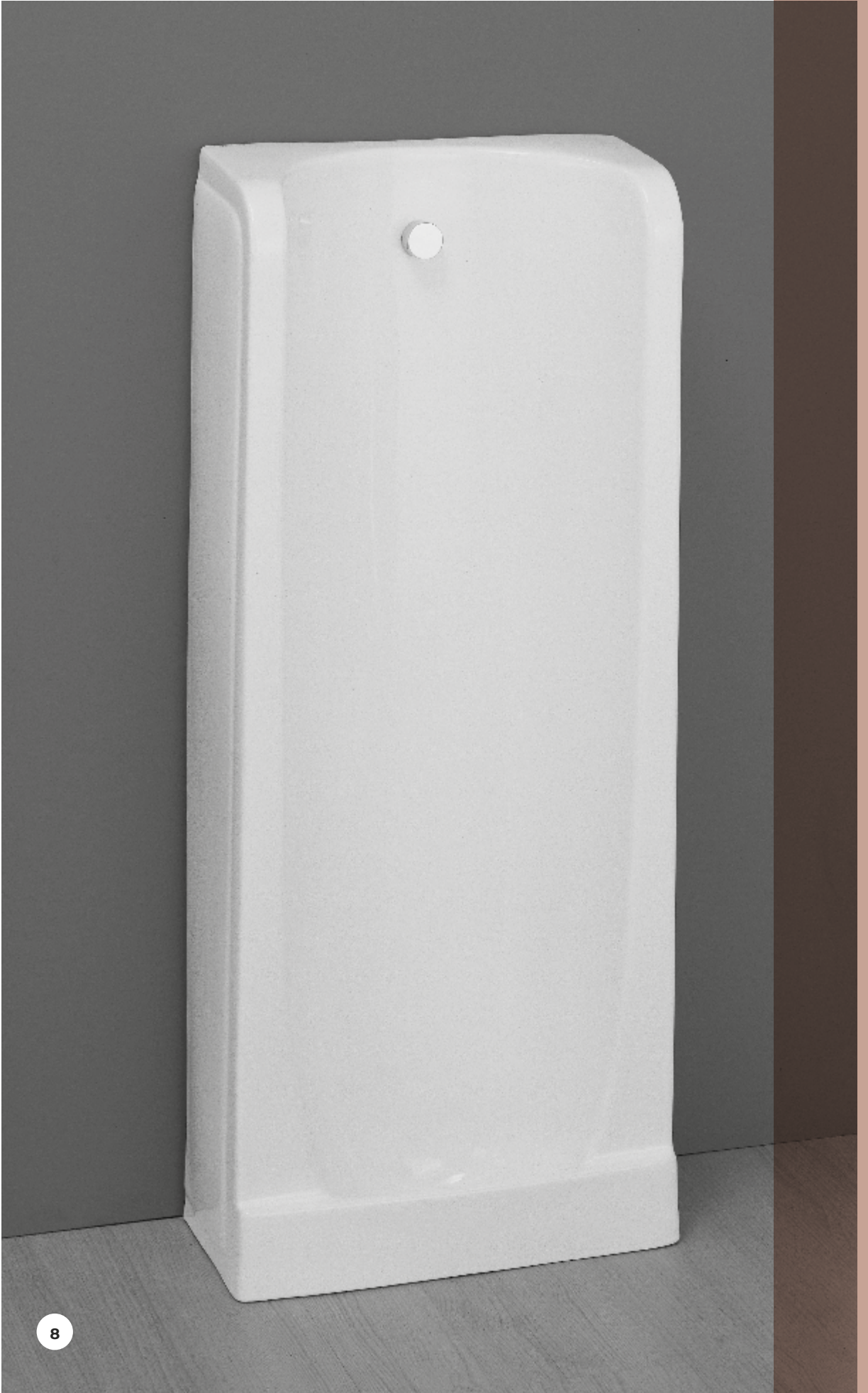



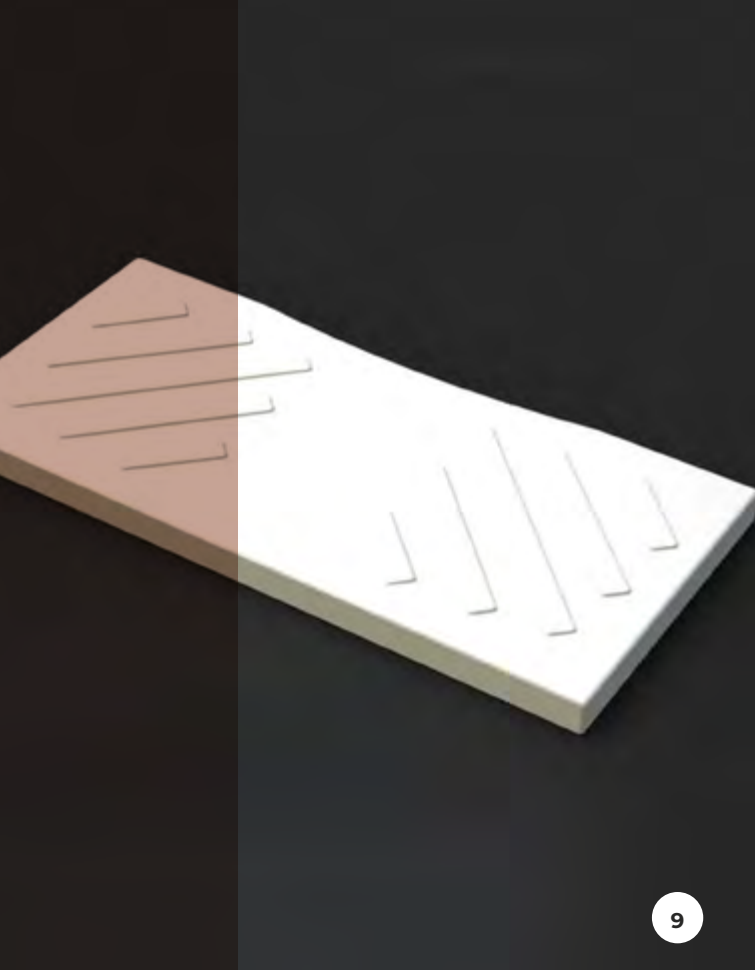

9

8 18521002K (48x22x110 cm)

9 18930002

10 18922002

11 18923002



11

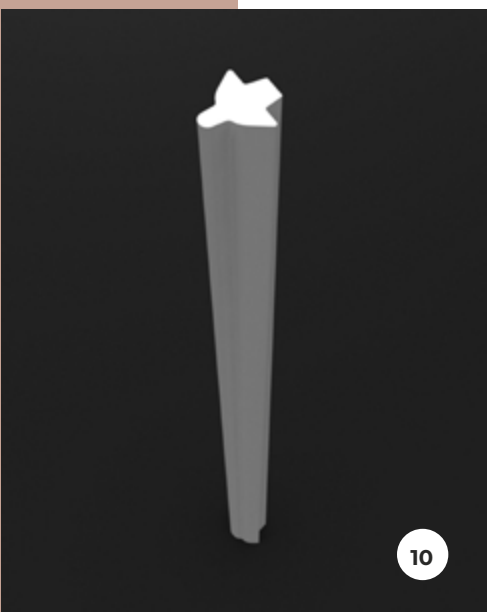

10

PEÇAS TÉCNICAS



PIEZAS TÉCNICAS



TECHNICAL PIECES



PIÈCES TECHNIQUES





# PEÇAS 3 técnicas

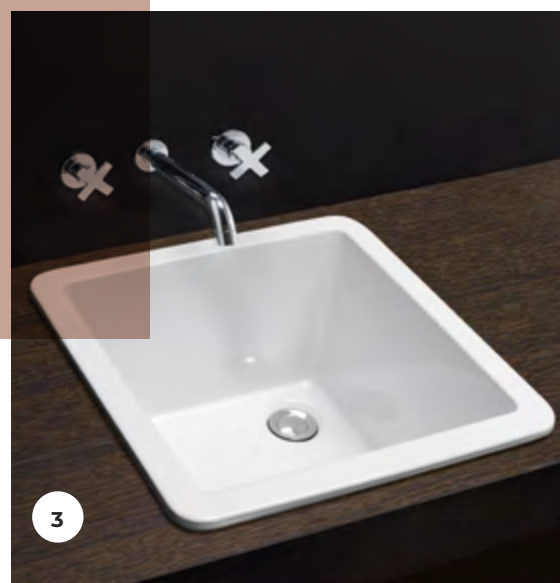



1 **78615002C** (48x38x19 cm)

2 **78616002C** (51x40x19 cm)

3 **78618002C** (46x46x27 cm)

4 **18613002K** (50x46x48 cm)  
**55003001**

5 **18614002** (32x32x22 cm)

6 **78660002** (52x45x27 cm)

7 **55332010** (51x44x81 cm)



LAVATÓRIOS



WASHBASINS



LAVABOS



LAVABOS





# Speciaux

SPECIALS | SPÉCIAUX







GRESANIT®

CERAMIC  
WARRANTY  
**20**  
years

PLATINIUM



- 
- 1 **79362002C** (120x43x13 cm)  
**79352002C** (110x43x13 cm)  
**79342002C** (100x43x13 cm)  
**79332002C** (90x43x13 cm)  
**79322002C** (80x43x13 cm)

- 2 **79361002C** (120x43x13 cm)  
**79351002C** (110x43x13 cm)  
**79341002C** (100x43x13 cm)  
**79331002C** (90x43x13 cm)  
**79321002C** (80x43x13 cm)  
**79301002C** (60x43x13 cm)

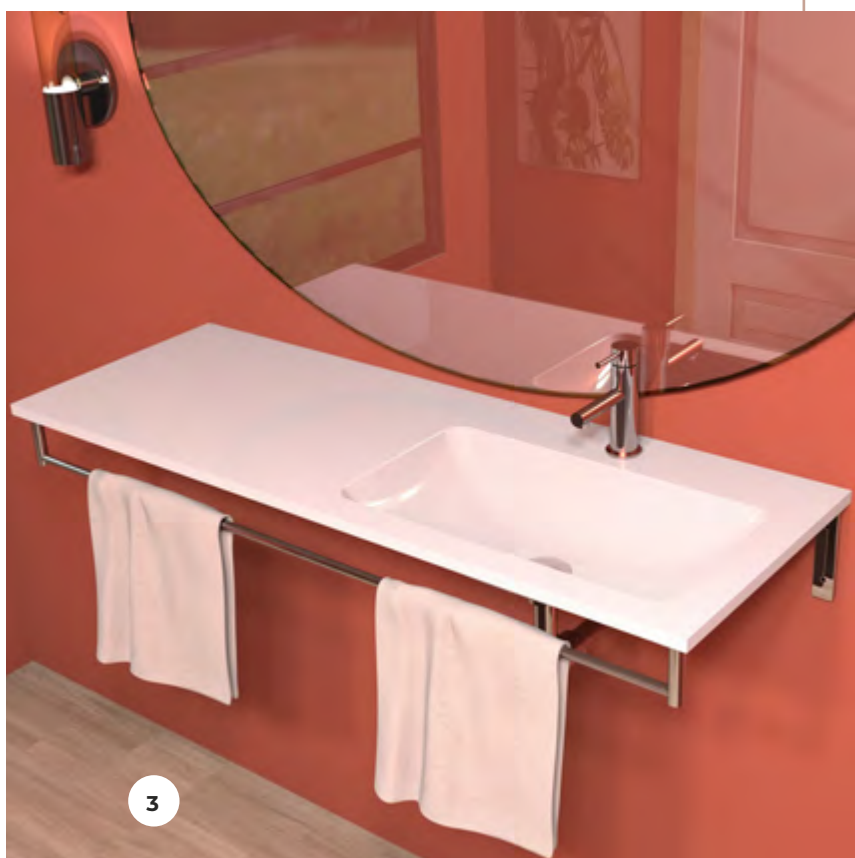

- 
- 3 **79363002C** (120x43x13 cm)  
**79353002C** (110x43x13 cm)  
**79343002C** (100x43x13 cm)  
**79333002C** (90x43x13 cm)  
**79323002C** (80x43x13 cm)

- 4 **55181100**

- 5 **55174120** 120  
**55174110** 110  
**55174100** 100  
**55174090** 90  
**55174080** 80  
**55174060** 60

PORTO



APOLO



- 1 **79620002C** (80x44x10 cm)  
**79621002C** (80x44x10 cm)
- 2 **55181002**
- 3 **55174080** 80
- 4 **16381002** (60x47x27 cm)  
**55182000** (60x47x27 cm)

## NEOCLÁSICO



- 5 **78331002C** 120  
**78321002C** 100  
**78311002C** 80
- 6 **50700042** 120 cromada  
**50700032** 100 cromada  
**50700022** 80 cromada
- 7 **70120002** (43x40x2 cm)  
**70100002** (43x30x2 cm)  
**70080002** (43x20x2 cm)

RAFAEL



- 
- 1 **79831002C** (120x46x12 cm)  
**79841002C** (120x46x12 cm)  
**79821002C** (100x46x12 cm)  
**79851002C** (100x46x12 cm)  
**79811002C** (80x46x12 cm)  
**79801002C** (60x46x12 cm)  
**79861002C** (50x46x12 cm)

- 2 **79842002C** (120x46x12 cm)

- 3 **79851002C** (100x46x12 cm)



- 
- 4 **55181009** 120  
**55181007** 100  
**55181005** 80  
**55181003** 60

- 5 **55181010** 120  
**55181008** 100  
**55181006** 80  
**55181004** 60

NEOCLÁSICO





1 16387002C (diâm. 45x15 cm)

2 55182033

3 78840002 (diâm. 40x12 cm)

4 55182013BR

## SERRAS



EGG

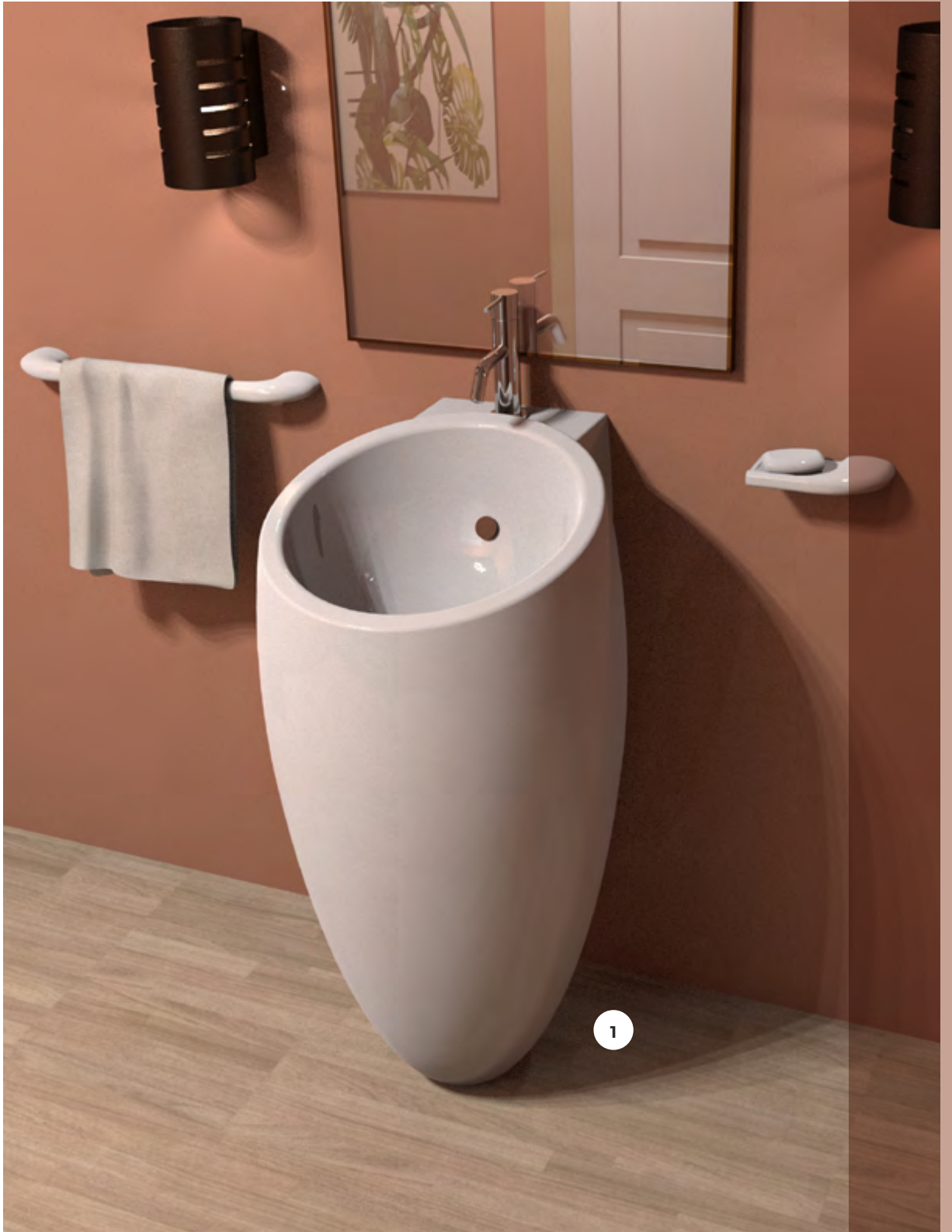



- 
- 1 **39881002C** (48x52x90 cm)
  - 2 **79910002C** (diâm. 45x82 cm)  
**79911002C** (diâm. 45x82 cm)
  - 3 **79900002C** (diâm. 40x44 cm)

RUBENS

KOBE



# Suspensos

SUSPENDIDOS | WALL HUNG | SUSPENDUS





GRESANIT®

CERAMIC  
WARRANTY  
20  
years

AVIZ



ONE LINE





- 
- 1 **79741002C** (100x40x10 cm)  
**79721002C** (80x40x10 cm)  
**79701002C** (60x40x10 cm)
  - 2 **40331002C** (120x45x12 cm)  
**40321002C** (100x45x12 cm)  
**40311002C** (80x45x12 cm)  
**40301002C** (60x45x12 cm)
  - 3 **55174140** 120  
**55174130** 100  
**55174080** 80  
**55174070** 60

## RECIFE PLUS

## GALLERY



- 
- 4 **78821002C** (76x50x12 cm)  
**78831002C** (76x50x12 cm)
  - 5 **78761002C** (45x45x10 cm)

# Lava Mãos

LAVA MANOS | HAND WASHBASINS | LAVE-MAINS







GRESANIT®

CERAMIC  
WARRANTY  
**20**  
years

ISIS



CANTO





5

- 
- 1 **78811002C** (53x28x12 cm)  
**78812002C** (53x28x12 cm)  
**78813002C** (53x28x12 cm)
  - 2 **18851002C** (33x32x11 cm)
  - 3 **18862002C** (44x36x10 cm)  
**18863002C** (44x36x10 cm)

### EUROPA

### EROS



2

### CEUTA



6

### VENUS



3

- 
- 4 **18307002C** (46x36x10 cm)
  - 5 **12361002C** (45x35x17 cm)
  - 6 **18801002C** (43x30x10 cm)  
**55174000**

# De pousar

SOBRE MUEBLE | STANDING | À POSER





GRESANIT®



AVIZ





- 
- 1 **79744002C** (100x40x10 cm)  
**79724002C** (80x40x10 cm)  
**79704002C** (60x40x10 cm)

- 2 **79441002C** (80x40x11 cm)  
**79431002C** (60x40x11 cm)  
**79421002C** (50x40x11 cm)  
**79411002C** (40x40x11 cm)

## VAN GOGH



## BARI

## CHAGALL 40



## CHAGAL



- 
- 3 **78867002C** (60x41x10 cm)
  - 4 **78850002C** (40x35x10 cm)
  - 5 **78860002C** (60x35x10 cm)  
**78865002C** (60x35x14 cm)

ISIS



MACAU







---

6 **78813002C** dir. (53x28x12 cm)  
**78812002C** esq. (53x28x12 cm)

7 **18711002C** (45x45x12 cm)

8 **78764002C** (45x45x10 cm)  
**78761002C** (45x45x10 cm)

## RECIFE PLUS

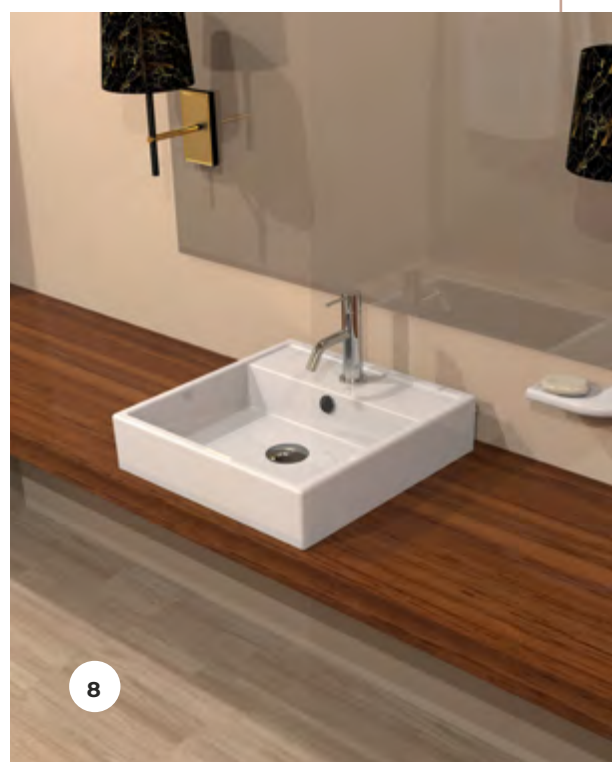

RIO

DAYTONA



---

9 **18817002C** (40x40x10 cm)

10 **78857002C** (41x41x10 cm)

MALMO



PICASSO





12

11 78871002C (54x30x13 cm)

12 39357002C (50x38x12 cm)

13 18890002C (50x40x15 cm)

18817002C

SAVOY



13

EGG

ONE BOLD



15

ONE SLIM



14

14 40357002C (47x35x13 cm)

15 40350002C (51x39x13 cm)

16 78357002C (50x30x13 cm)

MALIBU



DARK





18

17 78737002C (diâm. 42x13 cm)

18 78731002C (diâm. 42x13 cm)

19 79920002C (diâm. 44x21 cm)

ZEN



19

TAITI

URANO



21

BOSTON



20

20 18717002C (diâm. 41x16 cm)

21 18871002C (diâm. 45x10)

22 18797002C (diâm. 40x13cm)

TICIANO

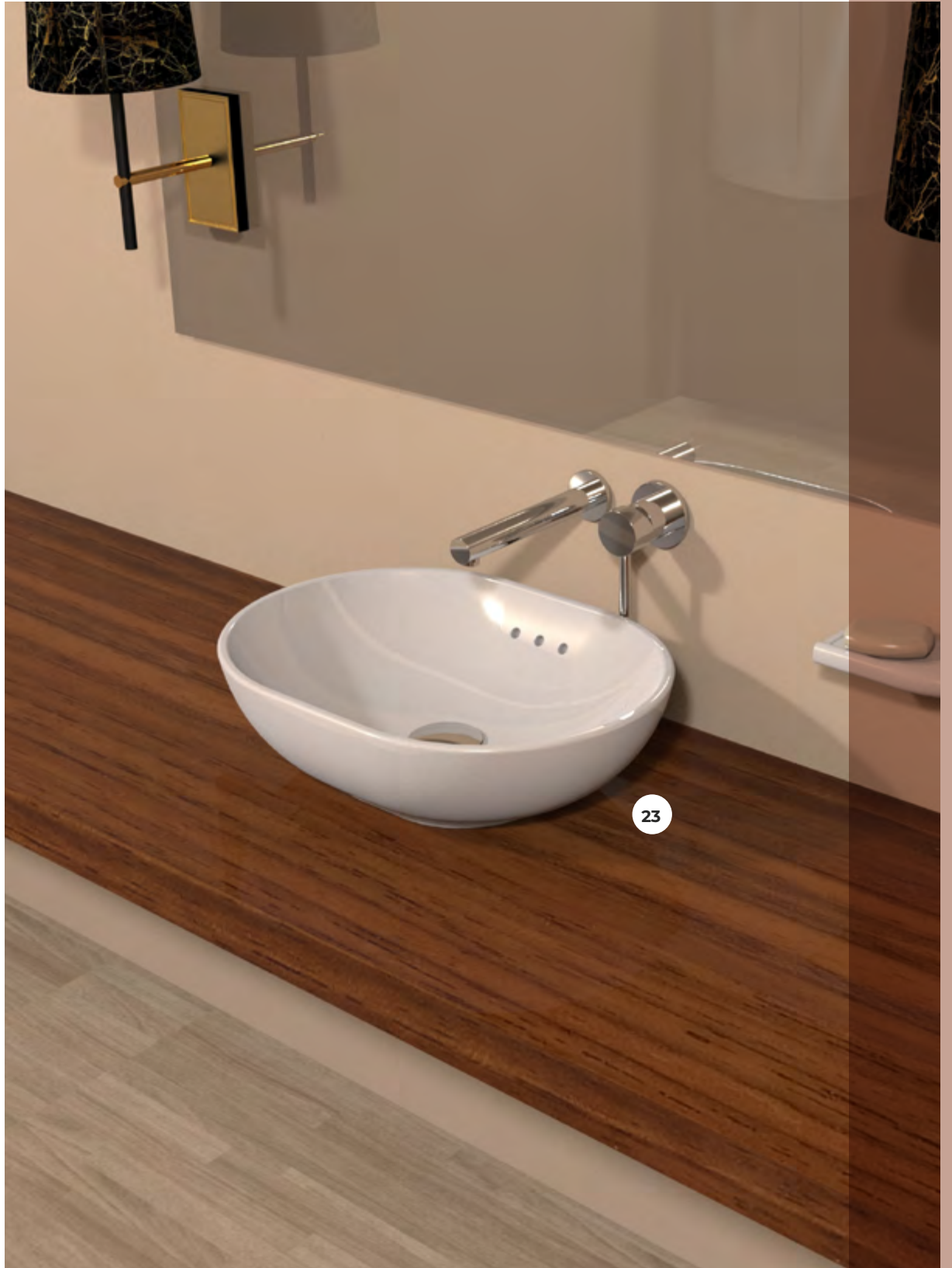

23



23 78891002C (45x33x13 cm)

24 18771002C (55x45x15 cm)

25 18701002C (63x49x13 cm)

ATLANTA

MIAMI



# De emboutir

SOBRE ENCIMERA | EMBEDDED | À ENCASTRER SUR MEUBLE







MONACO



OASIS





---

1 78707002C (diâm. 43x21 cm)

2 18361002C (57x50x22 cm)

MIRAMAR

PALM



---

3 18386002C (diâm. 41x21 cm)

4 18807002C (diâm. 40x13 cm)

5 18841002C (57x46x17 cm)

GOA

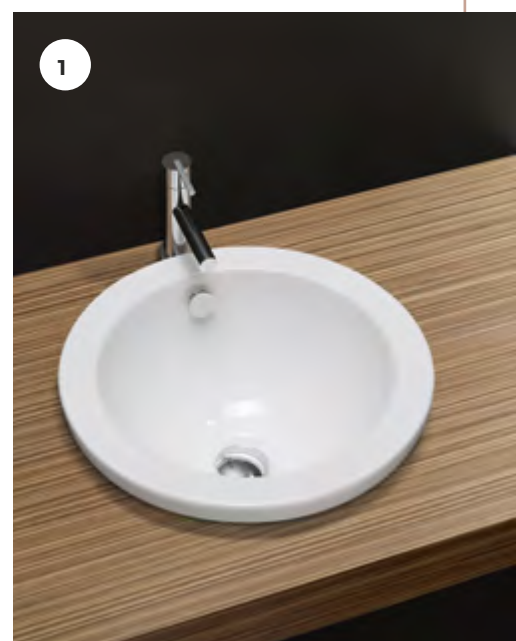

# Semi-emboutir

SEMI-ENTEGRAR | SEMI-EMBEDDED | SEMI-ENCASTRER





BARI





- 
- 1 **18881002C** (50x35x14 cm)
  - 2 **18341002C** (67x51x20 cm)
  - 3 **18751002C** (50x42x17 cm)

TORINO

ROMA



# De encastrar

BAJO ENCIMERA | RECESSED | À ENCASTRER EN DESSOUS



*Valadores*





OVAL



TOLEDO





MISSOURI

---

1 18327002C (58x46x21 cm)

2 18767002C (54x42x18 cm)

3 78868002C (65x38x8 cm)

DANUBIO

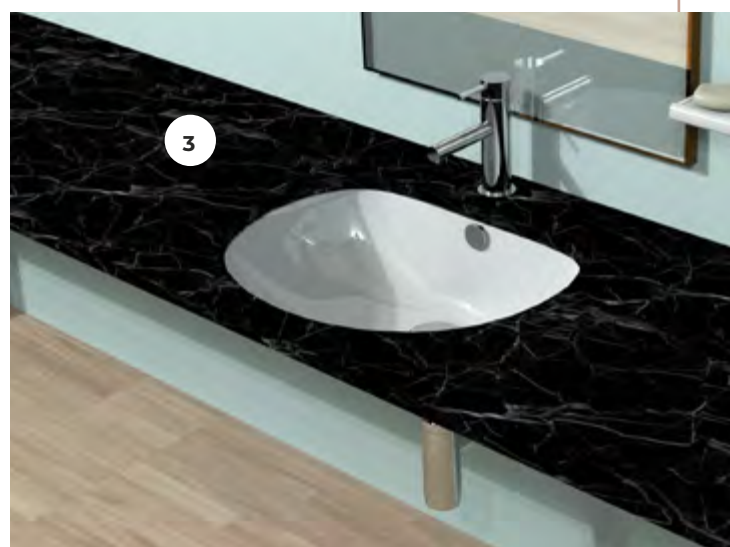

NICE



---

4 18381002C (diâm. 37x20 cm)

5 78868002C (60x38x8 cm)



- 
- 6 **18777002C** (55x35x16 cm)  
**18775002C** (50x34x16 cm)
  - 7 **18887002C** (diâm. 47x18 cm)

DALI



# PLACAS CERÂMICAS

encimeras en cerámica | ceramic tops | assiettes en céramique





- 
- 1 **70240002** (100x50x2 cm)
  - 70140002** (80x50x2 cm)
  - 70040002** (60x50x2 cm)

- 2 **55181001**

**GRESANIT®**



# ESTRUTURAS DE BANCADA

estructuras de encimera | top frames | structures pour assiettes

---

## PEDRAS STANDARD:

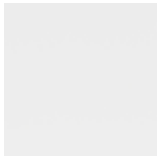

Crystal White



Granito Negro Absoluto

---

## PEDRAS OPCIONAIS:



Branco Carrara

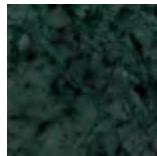

Indian Green



Marron Imperador Dark

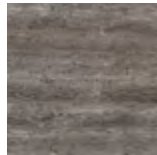

Teak Wood Grey



Travertino Italy





- 1 **52872083** (80x50x20 cm)  
**52872103** (100x50x20 cm)  
**52872123** (120x50x20 cm)

Bancada com pedra Branco Carrara

- 2 **52880083** (80x50x50 cm)  
**52880103** (100x50x50 cm)  
**52880123** (120x50x50 cm)

Bancada com pedra Cristal White

- 3 **52890083** (80x50x80 cm)  
**52890103** (100x50x80 cm)  
**52890123** (120x50x80 cm)

Bancada com pedra Cristal White

## ONOR

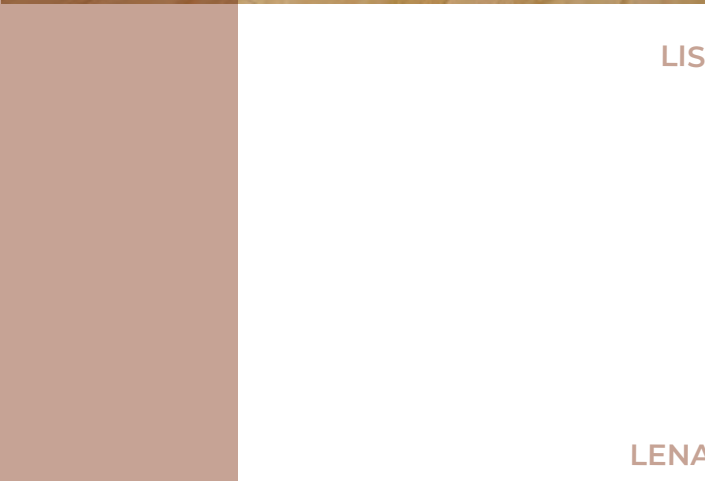
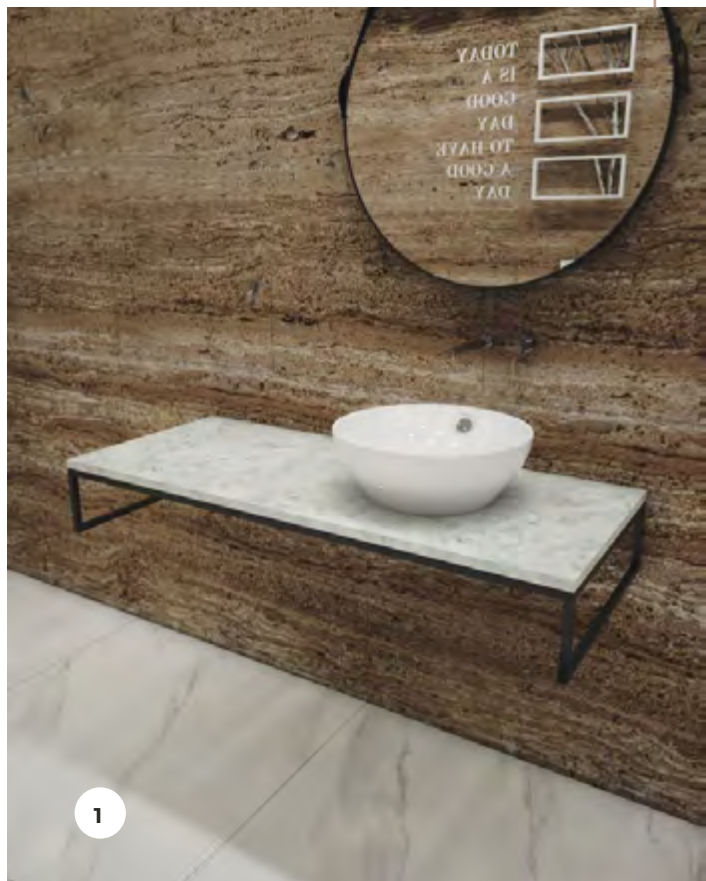

LIS



3

LENA

MÓVEIS



MUEBLES



FURNITURE



MEUBLES





# Móveis

FURNITURE | MUEBLES | MEUBLES





AVIZ



BOX





## BOX

- 1** **52805004** 100 c/ gavetão (99x39,5x50 cm)  
**52805002** 80 c/ gavetão (79x39,5x50 cm)  
**52805001** 60 c/ gavetão (59x39,5x50 cm)

**Outras opções:**

- Com gavetão e gaveta interior
- Com duas portas

**Acabamentos disponíveis:**

- Branco Brilho
- Preto brilho

- 2** **52815004** 120 (120x50x10 cm)  
**52815003** 100 (100x50x10 cm)  
**52815002** 80 (80x50x10 cm)  
**52815001** 60 (60x50x10 cm)

**Módulo de gaveta**

- 52817003** 100 (100x45x20 cm)  
**52817002** 80 (80x45x20 cm)  
**52817001** 60 (60x45x20 cm)

**Acabamentos disponíveis:**

- Branco Brilho
- Preto brilho
- Nogueira

- 3** **Box S/ tampo**  
**Para vz Platinium**  
**52826766** 120 c/ gavetão (119x42,5x50 cm)  
**52826765** 110 c/ gavetão (109x42,5x50 cm)  
**52826764** 100 c/ gavetão (99x42,5x50 cm)  
**52726763** 90 c/ gavetão (89x42,5x50 cm)  
**52826762** 80 c/ gavetão (79x42,5x50 cm)  
**52826761** 60 c/ gavetão (59x42,5x50 cm)

**Para Placa Cerâmica**

- 52825764** 100 s/ gavetão (109x49,5x50 cm)  
**52825762** 80 s/ gavetão (79x49,5x50 cm)  
**52825761** 60 s/ gavetão (59x49,5x50 cm)

**Outras opções:**

- Com gavetão e gaveta interior
- Com duas gavetas

**Acabamentos disponíveis:**

- Branco Brilho
- Preto brilho
- Nogueira

- 4** **Box c/ tampo**  
**52835486** 120 c/gavetão (119x49,5x50 cm)  
**52835484** 100 c/gavetão (99x49,5x50 cm)  
**52835482** 80 c/gavetão (79x49,5x50 cm)  
**52835481** 60 c/gavetão (59x49,5x50 cm)

**Outras opções:**

- Com gavetão e gaveta interior
- Com duas gavetas

**Acabamentos disponíveis:**

- Branco Brilho
- Preto brilho
- Nogueira

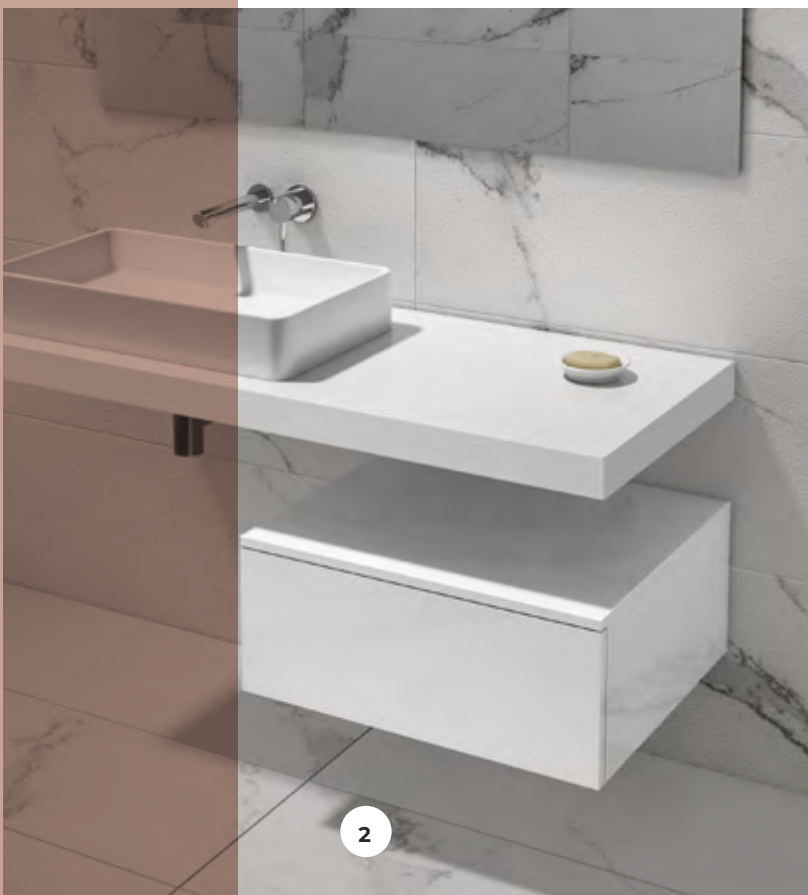

## TABLE

BASES DE CHUVEIRO



PLATOS DE DUCHA



SHOWER TRAYS



RECEVEURS DE DOUCHE







# Cerâmicas

CERAMICAS | CERAMICS | CÉRAMIQUES



EM GRASANIT |  
GRESANIT |  
EN GRESANIT |  
À GRESANIT |

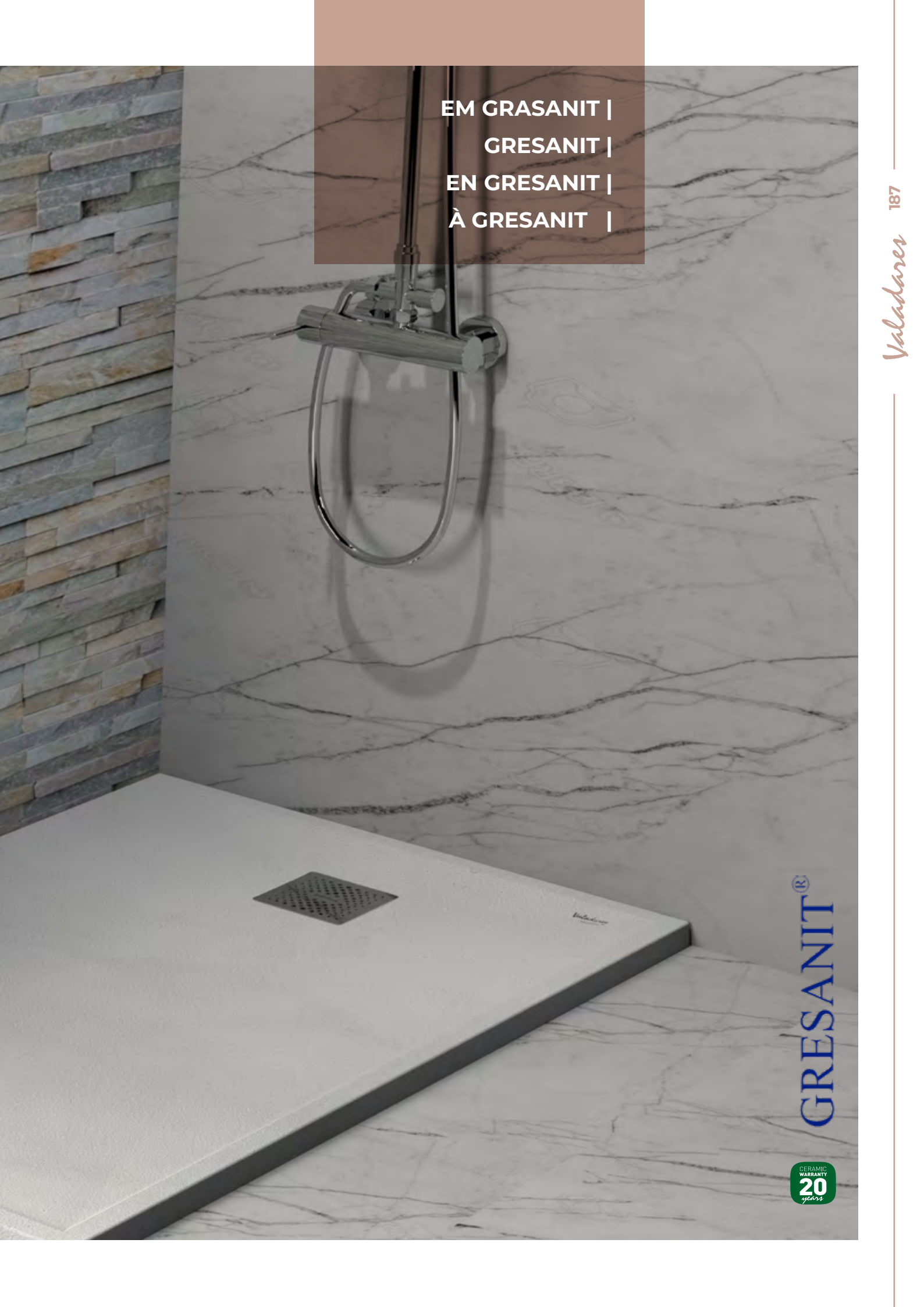

GRESANIT®

CERAMIC  
WARRANTY  
20  
years

FLOW





1

**78680002K** (80x80x3 cm)

**78681002K** (90x80x3 cm)

**78682002K** (100x80x3 cm)

**78683002K** (110x80x3 cm)

**78684002K** (120x80x3 cm)

**78686002K** (130x80x3 cm)

## CERÂMICA ANTIDERRAPANTE EM HIGHPOR

Revestimiento cerámico antideslizante

Non-slip ceramic coating

Céramique antidérapante en highpor



**Resistência  
às manchas**

**Resistencia a  
las manchas**

**Stain  
resistance**

**Résistance  
aux taches**



**Fácil  
limpeza**

**Fácil  
limpieza**

**Easy  
cleaning**

**Nettoyage  
facile**



**Resistência  
ao fogo**

**Resistente  
al fuego**

**Fire  
resistance**

**Résistance  
au feu**



**Resistência ao  
ataque químico**

**Resistencia al  
ataque químico**

**Resistance to  
chemical attack**

**Résistance aux  
attaques chimiques**

**Base 100% cerâmica e reciclável .  
Fácil escoamento e instalação.**

**HighPor® : Revestimento  
Cerâmico antiderrapante - Classe C**

**Plato de ducha 100% cerâmica y reciclable.  
Excelente flujo y facilidad de instalación.**

**HighPor®: Revestimiento cerámico  
antideslizante - Clase C**

**100% ceramic and recyclable shower tray.  
Excellent flow and ease of installation.**

**HighPor®: Non-slip ceramic coating - Class C**

**Céramique antidérapante en Highpor  
Receveur de douche 100% céramique recyclable  
Écoulement et installation facile**

**Highpor: Revêtement céramique antidérapant classe C**

LUCA

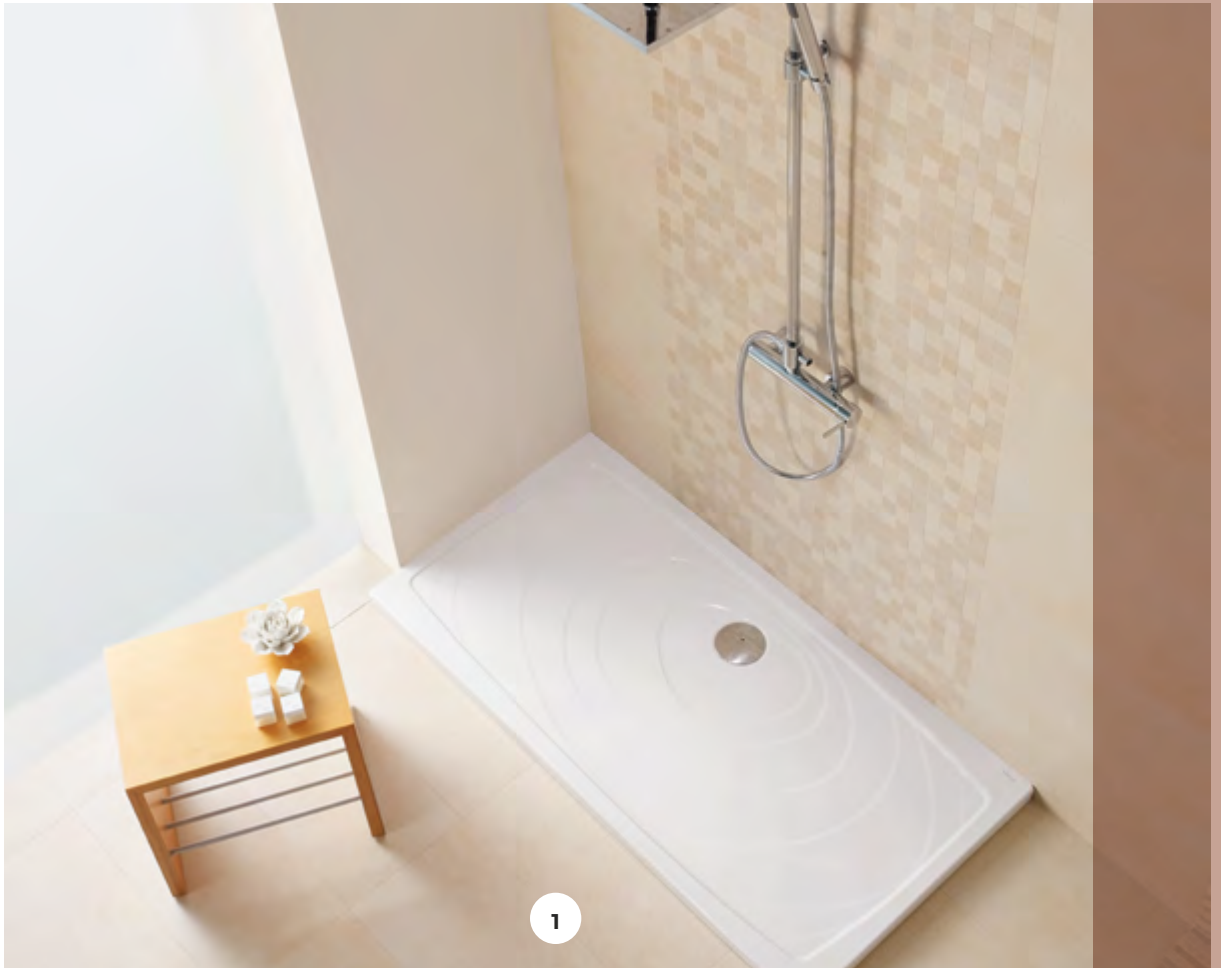

EGG

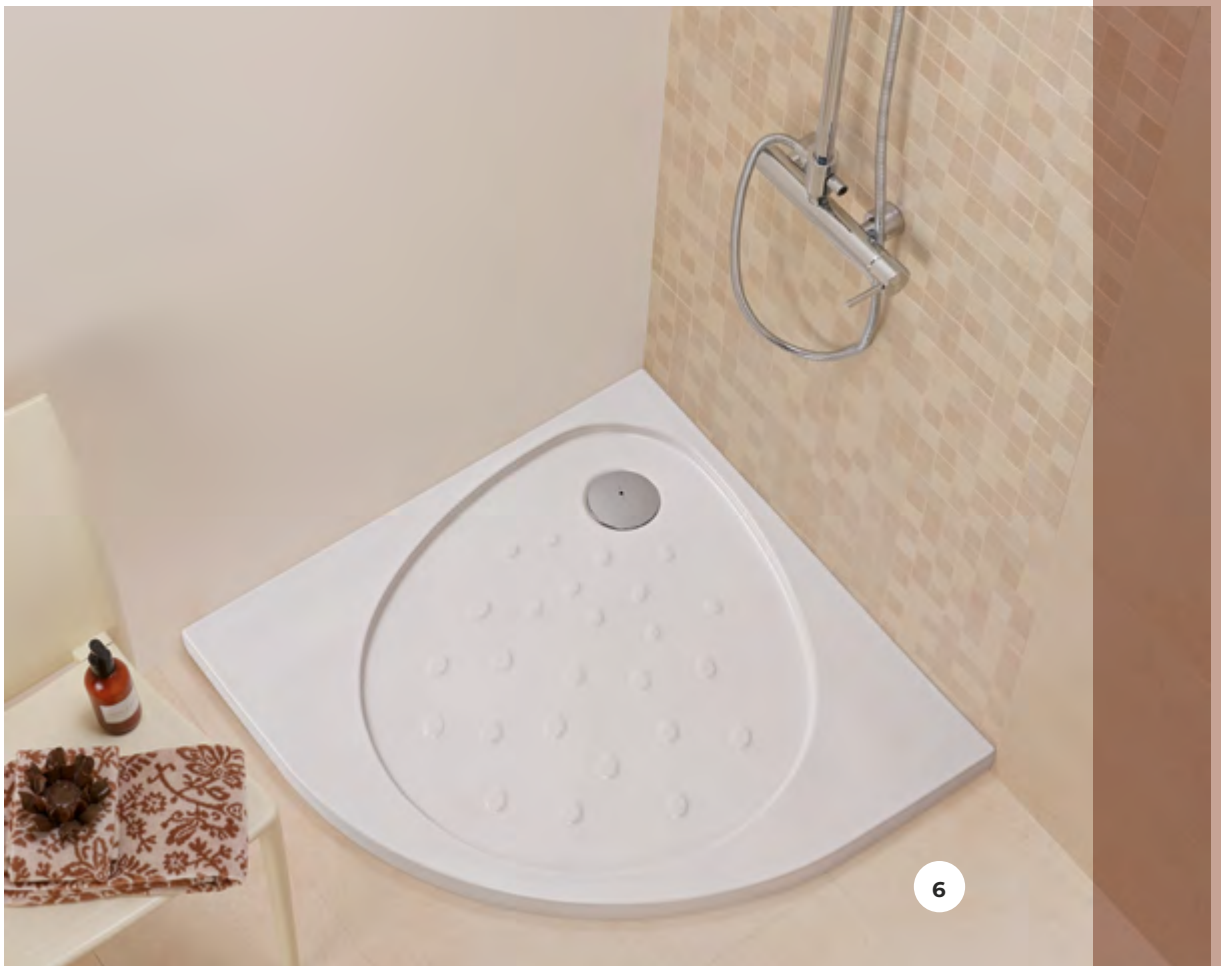

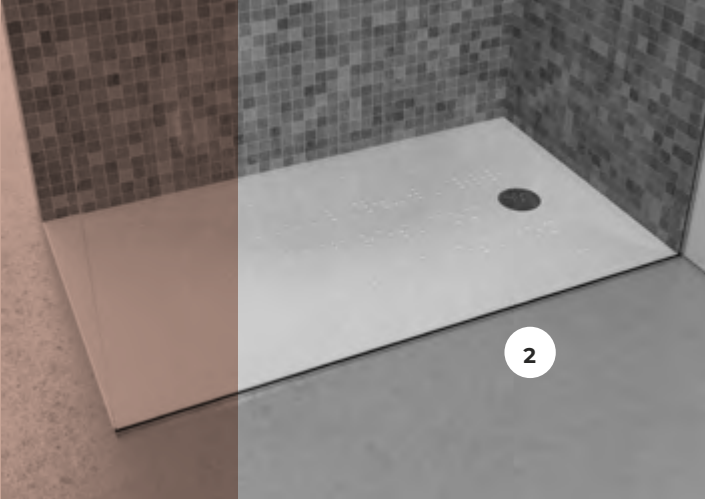

- 
- 1 **78672002K** (140x80x5 cm)  
**78671002K** (140x70x5 cm)
  - 2 **78674002K** (130x80x4 cm)  
**78673002K** (130x75x4 cm)
  - 3 **78636002K** (120x80x5 cm)  
**78635002K** (100x80x5 cm)

## BERNA

## PÁDUA

## AQUA

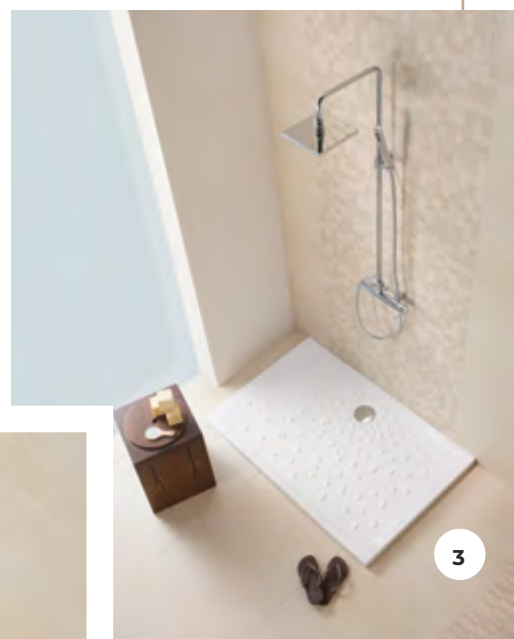

## ARIS



- 
- 4 **78634002K** (120x70x4 cm)  
**78633002K** (100x70x4 cm)
  - 5 **78639002K** (90x90x6 cm)
  - 6 **39673002K** (90x90x5 cm)

LUSA



DOURO PLUS

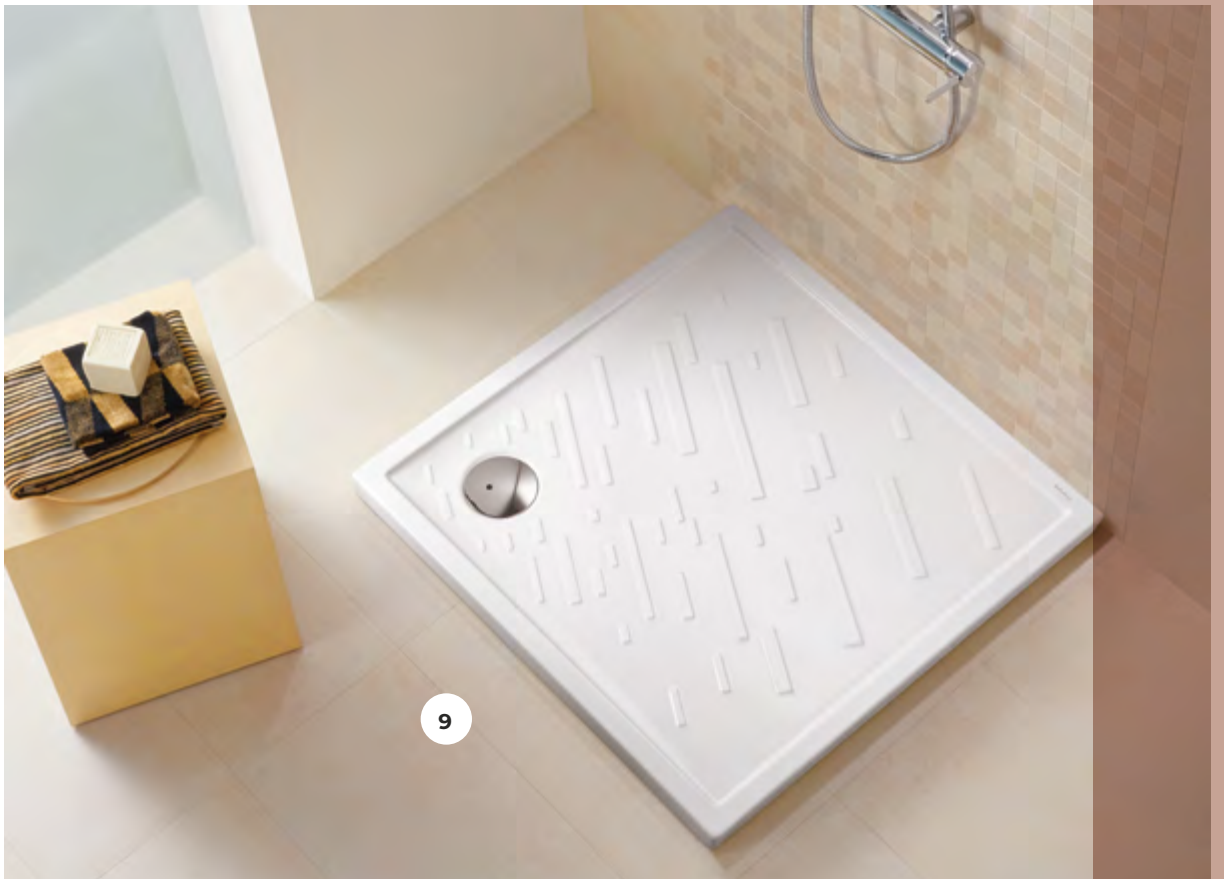



7 78632002K (90x70x6 cm)

8 78631002K (90x70x5 cm)

9 78670002K (80x80x5 cm)

## DANILO



IKO

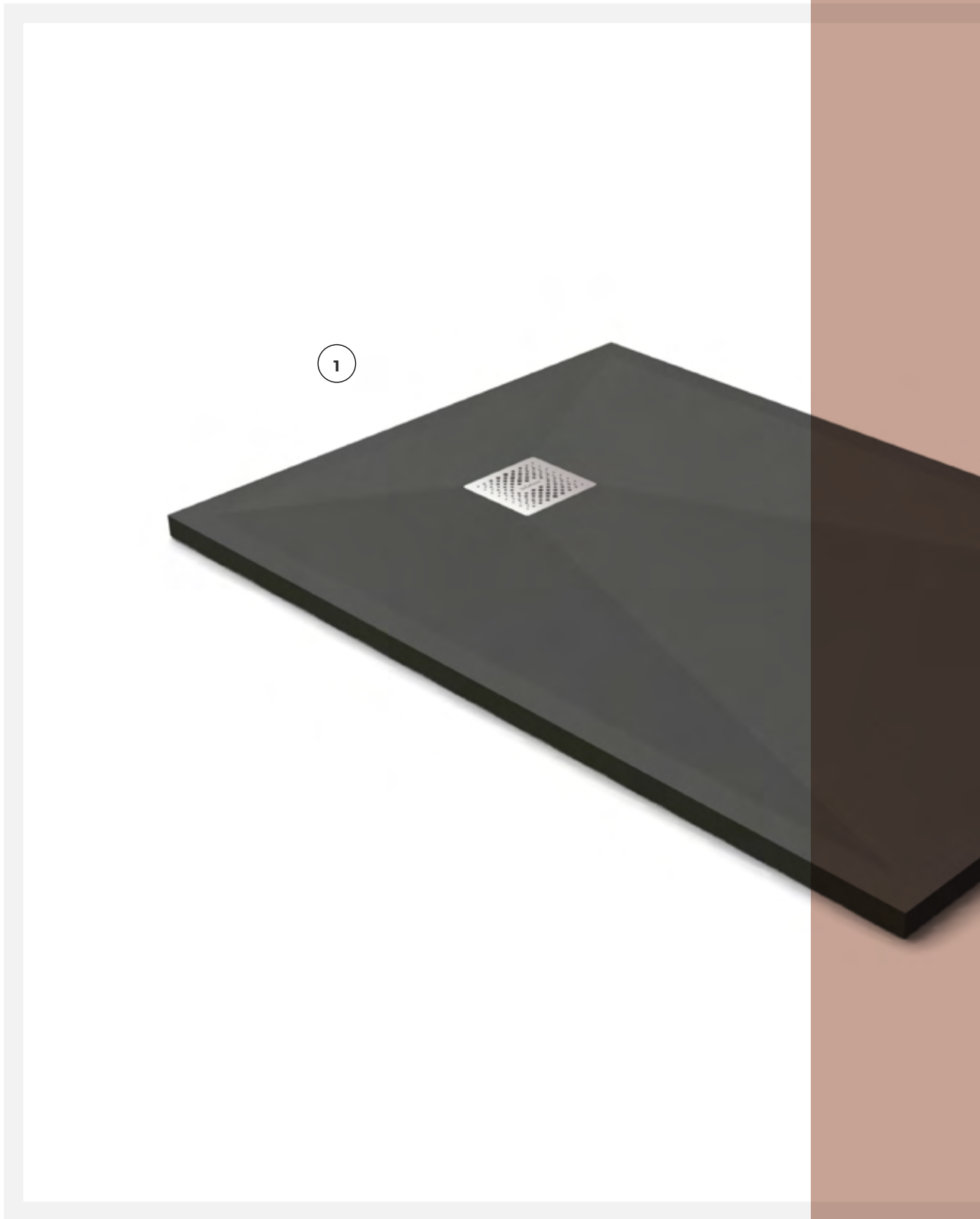

EM RESINA | IN RESIN | EN RESINA | EN RÉSINE

1

**52504000** (120x120x3 cm)  
**52503000** (110x110x3 cm)  
**52502000** (100x100x3 cm)  
**52501000** (90x90x3 cm)  
**52500000** (80x80x3 cm)  
**52505000** (70x70x3 cm)

**52597000** (220x120x3 cm)  
**52596000** (220x110x3 cm)  
**52565000** (220x100x3 cm)  
**52564000** (220x90x3 cm)  
**52563000** (220x80x3 cm)  
**52595000** (220x75x3 cm)  
**52594000** (220x70x3 cm)

**52593000** (210x120x3 cm)  
**52592000** (210x110x3 cm)  
**52562000** (210x100x3 cm)  
**52561000** (210x90x3 cm)  
**52560000** (210x80x3 cm)  
**52591000** (210x75x3 cm)  
**52590000** (210x70x3 cm)

**52589000** (200x120x3 cm)  
**52588000** (200x110x3 cm)  
**52559000** (200x100x3 cm)  
**52558000** (200x90x3 cm)  
**52557000** (200x80x3 cm)  
**52587000** (200x75x3 cm)  
**52586000** (200x70x3 cm)

**52585000** (190x120x3 cm)  
**52584000** (190x110x3 cm)  
**52556000** (190x100x3 cm)  
**52555000** (190x90x3 cm)  
**52554000** (190x80x3 cm)  
**52553000** (190x75x3 cm)  
**52552000** (190x70x3 cm)

**52583000** (180x120x3 cm)  
**52582000** (180x110x3 cm)  
**52570000** (180x100x3 cm)  
**52569000** (180x90x3 cm)  
**52568000** (180x80x3 cm)  
**52567000** (180x75x3 cm)  
**52566000** (180x70x3 cm)

**52581000** (170x120x3 cm)  
**52580000** (170x110x3 cm)  
**52551000** (170x100x3 cm)  
**52550000** (170x90x3 cm)  
**52549000** (170x80x3 cm)  
**52548000** (170x75x3 cm)  
**52547000** (170x70x3 cm)

**52579000** (160x120x3 cm)  
**52578000** (160x110x3 cm)  
**52546000** (160x100x3 cm)  
**52545000** (160x90x3 cm)  
**52544000** (160x80x3 cm)  
**52543000** (160x75x3 cm)  
**52542000** (160x70x3 cm)

**52577000** (150x120x3 cm)  
**52576000** (150x110x3 cm)  
**52541000** (150x100x3 cm)  
**52540000** (150x90x3 cm)  
**52539000** (150x80x3 cm)  
**52538000** (150x75x3 cm)  
**52537000** (150x70x3 cm)

**52575000** (140x120x3 cm)  
**52574000** (140x110x3 cm)  
**52536000** (140x100x3 cm)  
**52535000** (140x90x3 cm)  
**52534000** (140x80x3 cm)  
**52533000** (140x75x3 cm)  
**52532000** (140x70x3 cm)

**52573000** (130x120x3 cm)  
**52572000** (130x110x3 cm)  
**52531000** (130x100x3 cm)  
**52530000** (130x90x3 cm)  
**52529000** (130x80x3 cm)  
**52528000** (130x75x3 cm)  
**52527000** (130x70x3 cm)

**52571000** (120x110x3 cm)  
**52526000** (120x100x3 cm)  
**52525000** (120x90x3 cm)  
**52524000** (120x80x3 cm)  
**52523000** (120x75x3 cm)  
**52522000** (120x70x3 cm)

**52521000** (110x100x3 cm)  
**52520000** (110x90x3 cm)  
**52519000** (110x80x3 cm)  
**52518000** (110x75x3 cm)  
**52517000** (110x70x3 cm)

**52516000** (100x90x3 cm)  
**52515000** (100x80x3 cm)  
**52514000** (100x75x3 cm)  
**52513000** (100x70x3 cm)

**52512000** (90x80x3 cm)  
**52511000** (90x75x3 cm)  
**52510000** (90x70x3 cm)

**52506000** (80x75x3 cm)  
**52507000** (80x70x3 cm)

RESGUARDOS



MAMPARAS



SHOWER CABINS



PANNEAUX DOUCHE





# Resguardos

MAMPARAS | SHOWER CABINS | PANNEAUX DE DOUCHE





OPALA



RUBI





## PURA



5

- 
- 1 52762072D/E 1401-1600  
52762062D/E 1201-1400  
52762052D/E 1000-1200
  - 2 52762102D/E 1401-1600 x 800  
52762092D/E 1201-1400 x 800  
52762082D/E 1000-1200 x 800
  - 3 52762022D/E 801-1000  
52762012D/E 640-800
  - 4 52762042D/E 801-1000 x 800  
52762032D/E 640-800 x 800

## SPLASH FRONTAL



6

- 
- 5 52763232 120  
52763222 100  
52763212 90  
52763202 80
  - 6 52763162 160  
52763152 150  
52763142 140  
52763132 130  
52763122 120  
52763112 110  
52763102 100

SPLASH MÓDULOS



1

**52763052** módulo 120 (118,5 - 120)**52763042** módulo 100 (98,5 - 100)**52763032** módulo 90 (88,5 - 90)**52763022** módulo 80 (78,5 - 80)**52763012** módulo 75 (73,5 - 75)**52763002** módulo 70 (68,5 - 70)

Cabine de canto com painéis fixos e portas de correr de abertura central. Produzidas com perfis de alumínio cromado brilhante e vidro temperado de 6mm de espessura e 2,00m de altura. Vidro com tratamento anticalcário (easy cleaning)

Dimensão do resguardo	Dimensión de la mampara	Cabine dimension	Módulos/ Modules
	70x70		52763002 + 52763002
	75x75		52763012 + 52763012
	80x80		52763022 + 52763022
	90x90		52763032 + 52763032
	100x100		52763042 + 52763042
	120x120		52763052 + 52763052
	80x70		52763022 + 52763002
	90x70		52763032 + 52763002
	100x70		52763042 + 52763002
	120x70		52763052 + 52763002

Dimensão do resguardo	Dimensión de la mampara	Cabine dimension	Módulos/ Modules
	80x75		52763022 + 52763012
	90x75		52763032 + 52763012
	100x75		52763042 + 52763012
	120x75		52763052 + 52763012
	90x80		52763032 + 52763022
	100x80		52763042 + 52763022
	120x80		52763052 + 52763022

EGG



2

**52750201** 90

Com dois painéis fixos e duas portas de correr. Produzidos com perfis de alumínio metalizado e vidro temperado de 4mm. Rolamentos de esferas em inox. Altura de 185 cm.

2

BANHEIRAS



BAÑERAS



BATHTUBS



BAIGNOIRES





# Freestanding

BATHTUBS | BAÑERAS | BAIGNOIRES

Vala

ORIGINAL

SING



EM RESINA ACRÍLICA COM CARGA MINERAL |  
IN ACRYLIC RESIN WITH MINERAL LOAD |  
EN RESINA ACRÍLICA CON CARGA MINERAL |  
EN RÉSINE ACRYLIQUE À CHARGE MINÉRALE |

*Valadares*

BATHROOMS

CE 1921



EGG







1 **52100000** (170x70x50 cm)

2 **51100204** (190x100x53 cm)

3 **51100203** (170x80x64 cm)

4 **511002060** (170x72x55 cm)

## ZEN

## PURE



## MOON

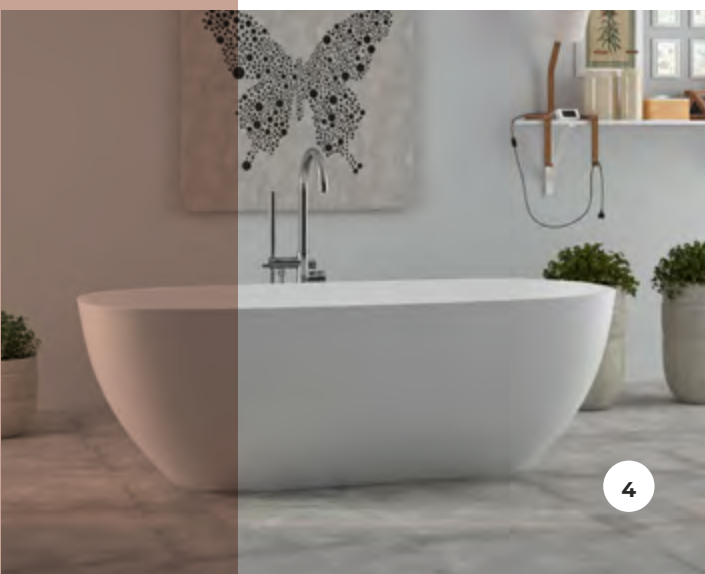

LUX

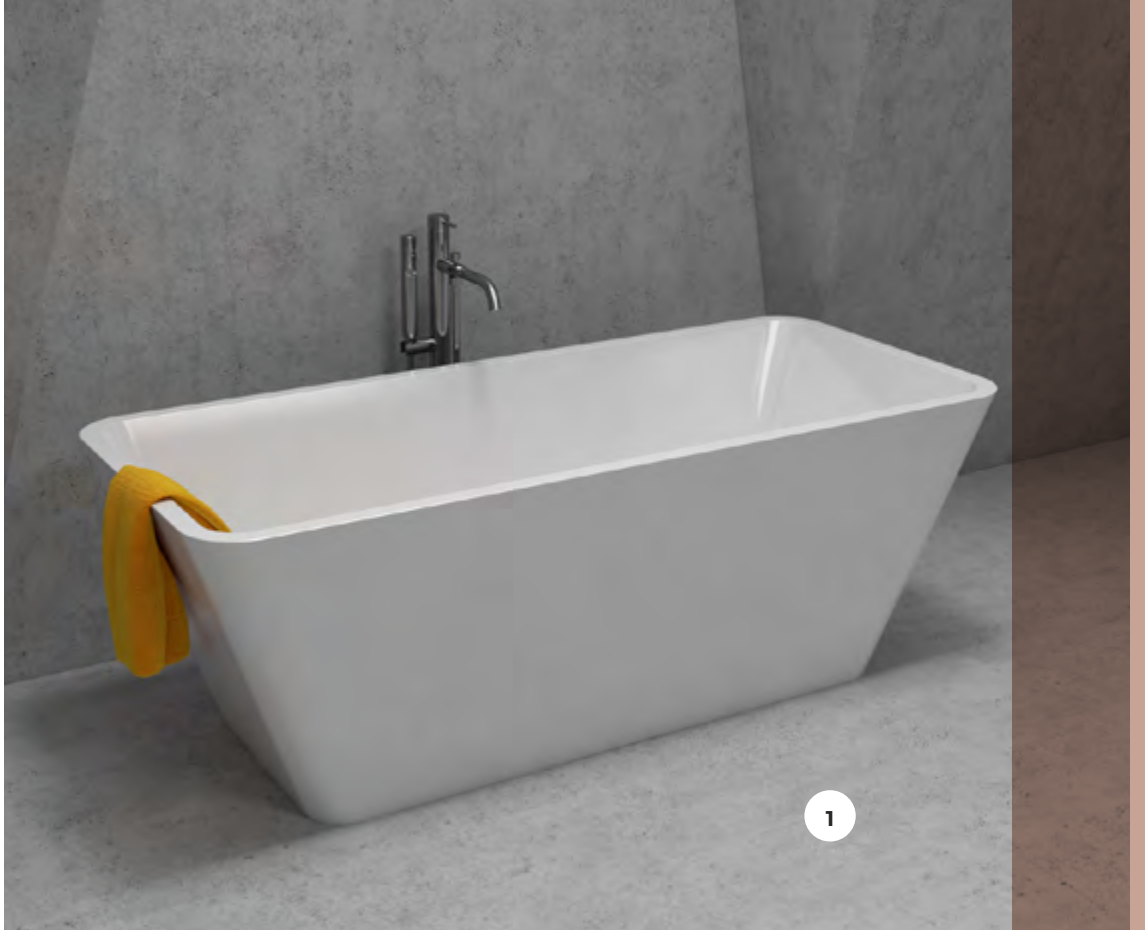

LOOK



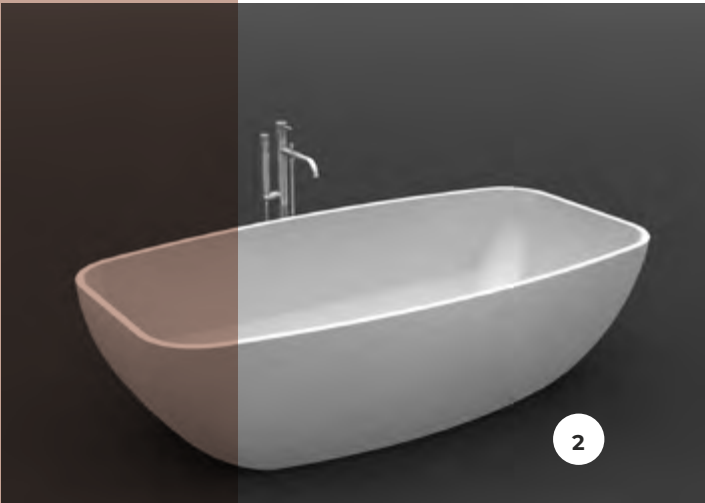

1 **51100202** (164x70x58 cm)

2 **51100201** (178x84x63 cm)

3 **51100203** (180x88x57 cm)

4 **51100002** (168x76x65 cm)  
**51100001** (175x82x72 cm)

5 **51200002**

## STAR

## LINEA



## CLASSIC



Banheiras Classic fornecidas com pés e sistema de esgoto cromados.

Em opção, os pés e o sistema de esgoto podem ser em branco ou em cobre velho.

PLATANO



EM ACRÍLICO | IN ACRYLIC | EN ACRILICO | EN ACRYLIQUE

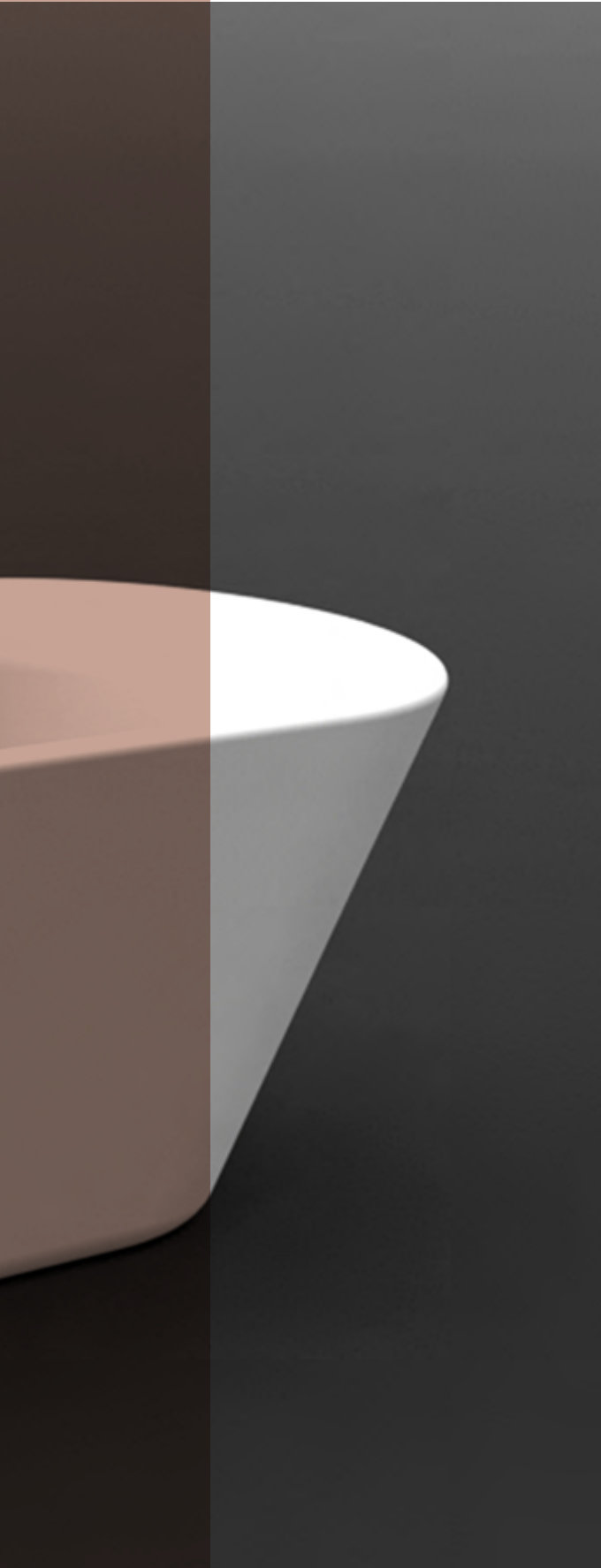

1

51101001 (176x80x62 cm)

51101002 (158x70x62 cm)

TORNEIRAS



GRIFOS



TAPS



ROBINETS





# Torneiras

TAPS | GRIFOS | ROBINETS







# LUNA

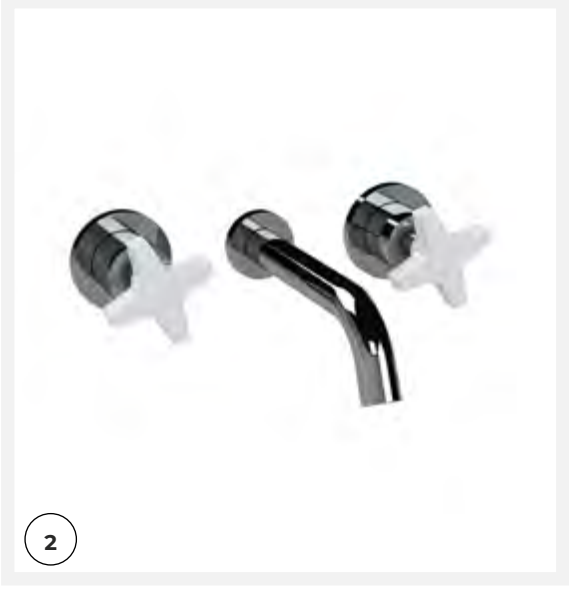
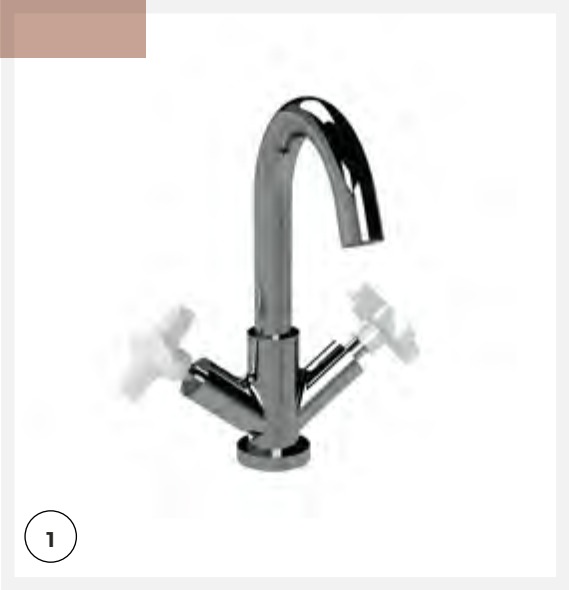
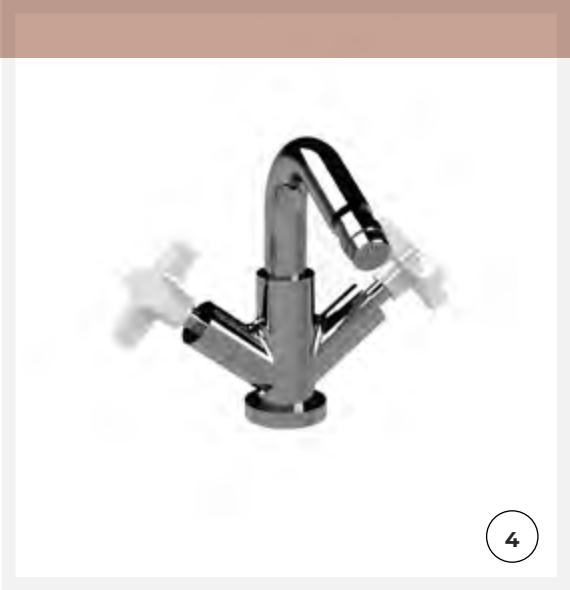

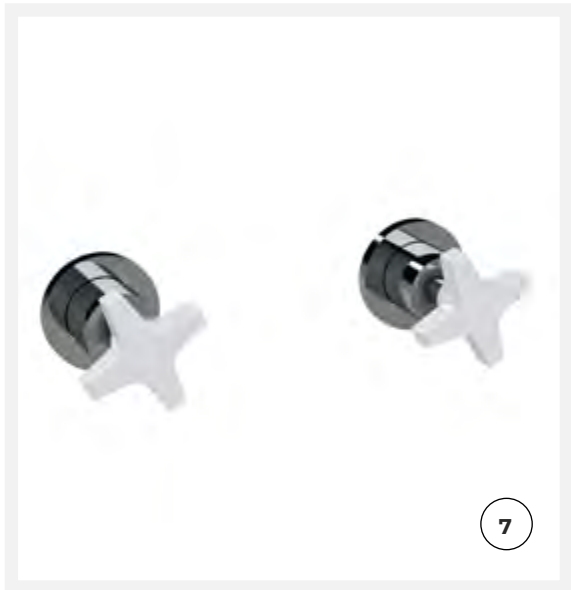

7

1 5062102200

2 5062122200

3 5062132200

4 5062104200

5 5062105200

6 5062106200

7 5062107200

8 5062127200  
5062137200

9 5511002200

10 5062139200  
5062149200

11 5062119200  
5062129200

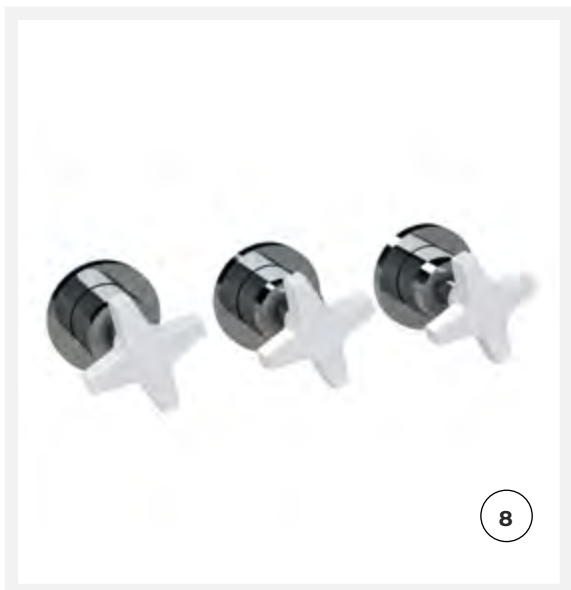

8



10

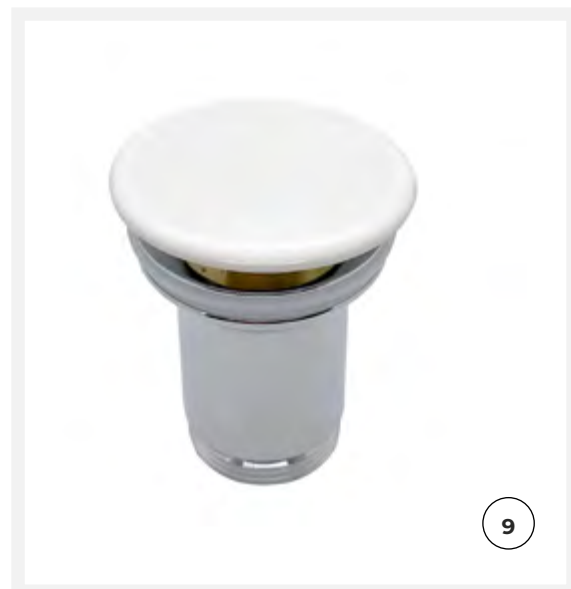

9



11

# LOTTO

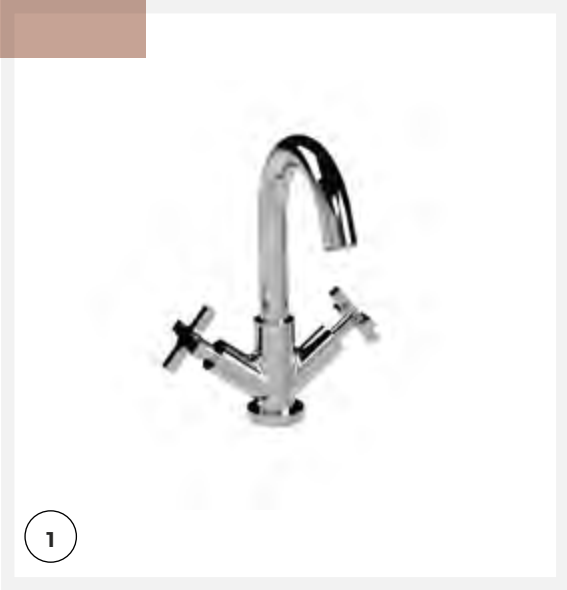
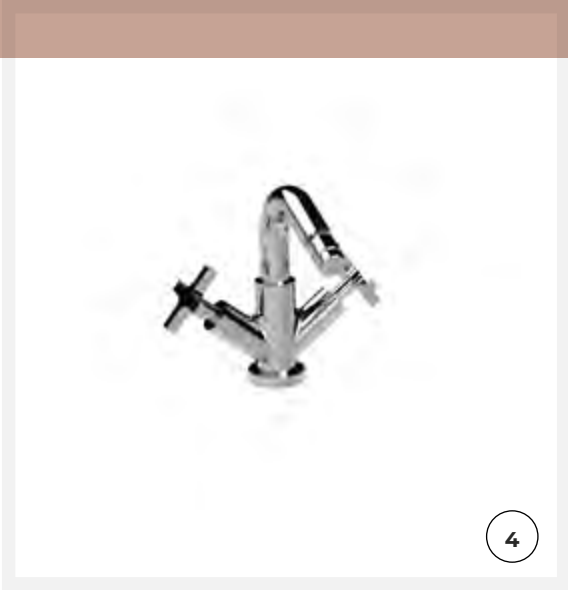



7

1 50662022

2 50662222

3 50662322

4 50662042

5 50662052

6 50662152

7 50662062

8 50662072

9 50662272  
50662372

10 50662192  
50662292

11 50662392  
50662492



8

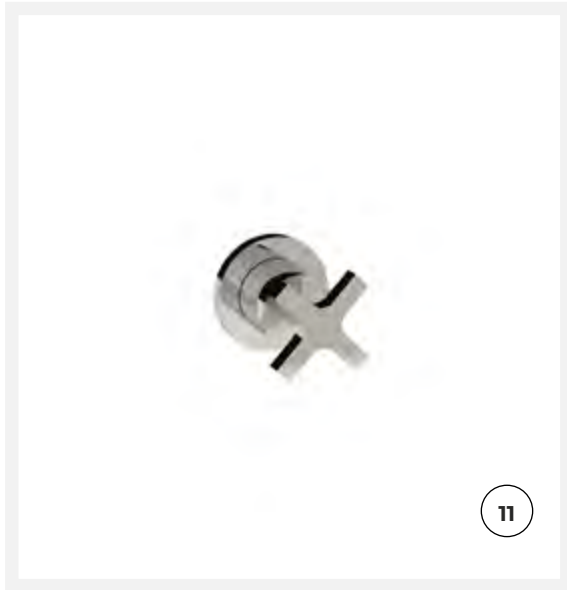

11

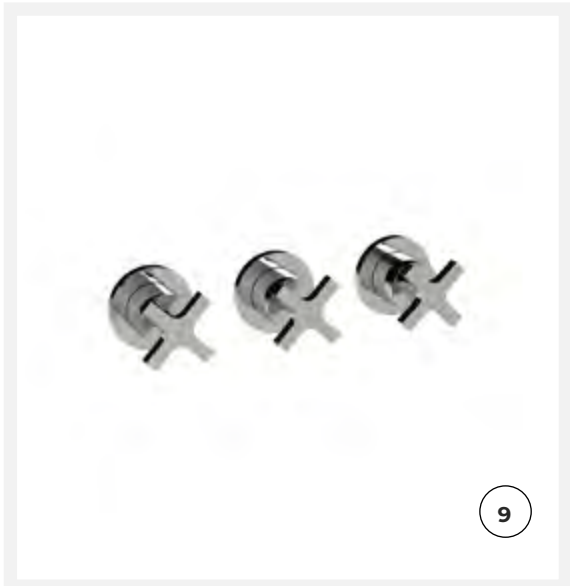

9

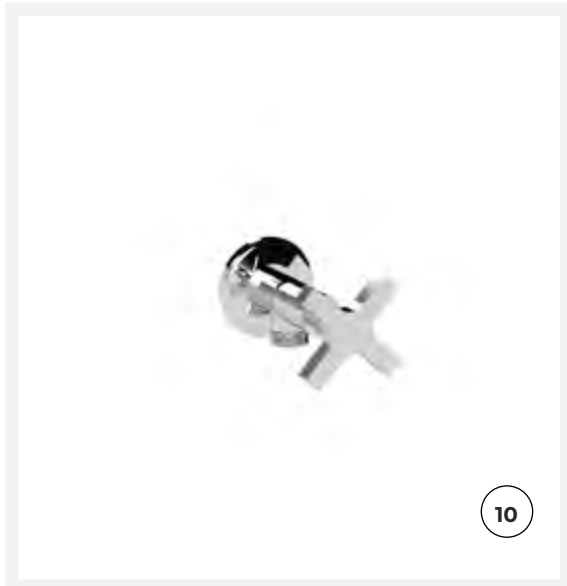

10

# LINE

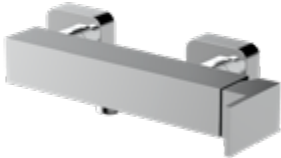

4



1



5

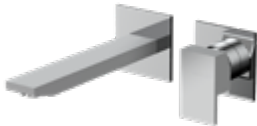

2



6



3



1 50613022

2 50613322

3 50613052

4 50613062

5 50613072

6 50613172

7 50613272  
50613372

8 50613972

9 50613142

10 50613672

11 50613042

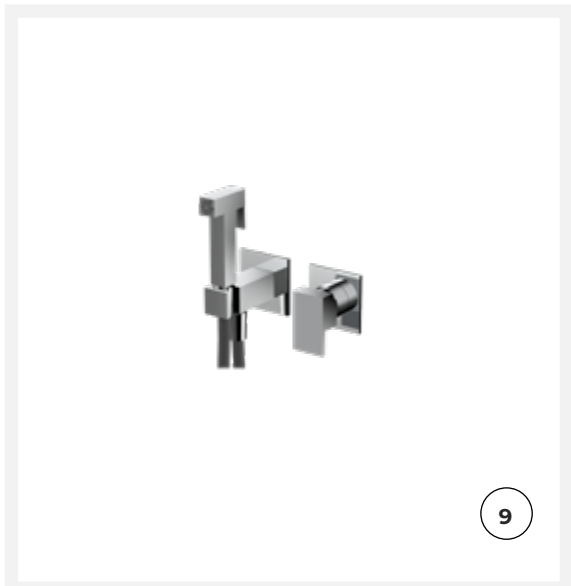
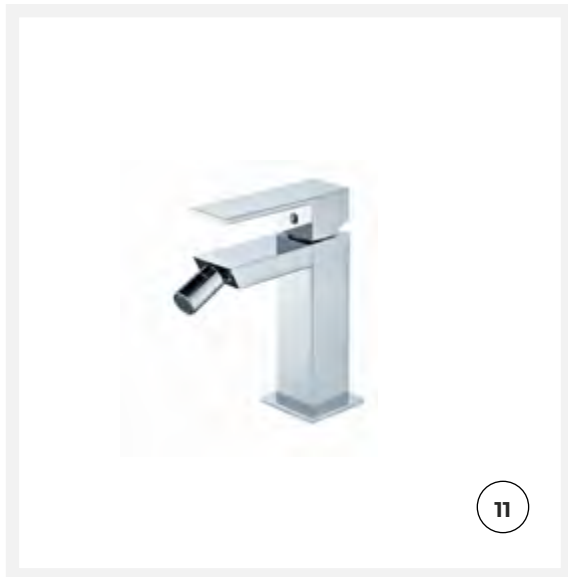

# CLASSIC



4



1



5



2



6



3





1 50635022

2 50635312

3 50635222

4 50635042

5 50635342

6 50635052

7 50635152

8 50635062

9 50635072

10 50635272  
50635372

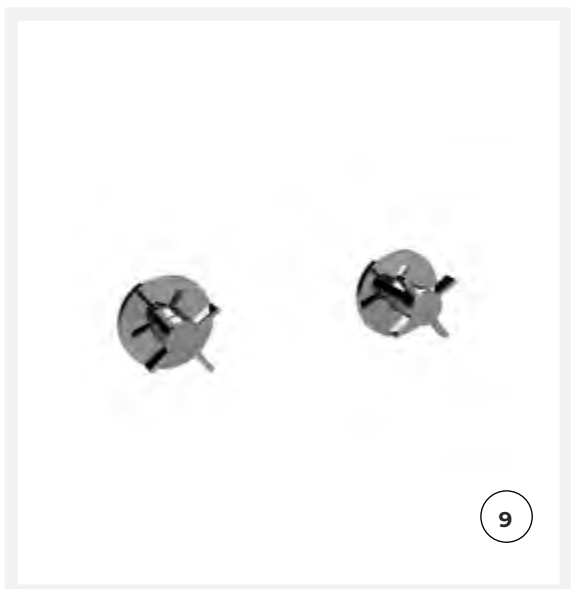
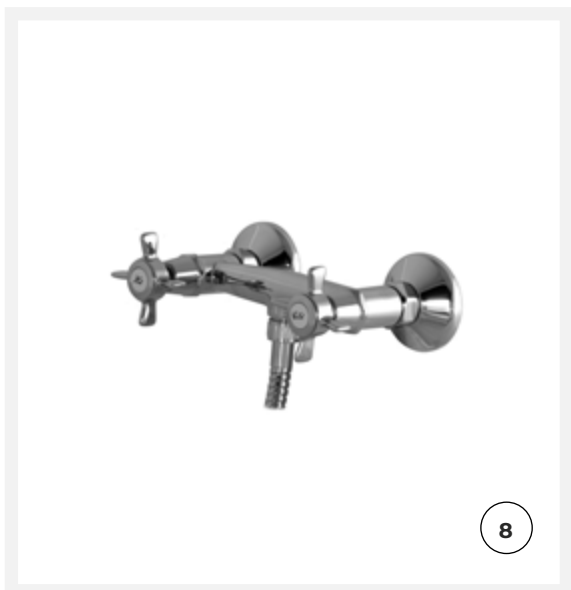

# CLASSIC



---

11 50635252

12 50635472

13 50935922

14 50935912



# CAYENNE

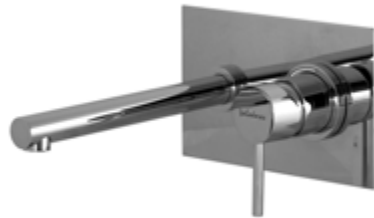

4



1



5



2



6



3



7

1 50615022

2 50615322

3 50615122

4 50615222

5 50615622

6 50615042

7 50615052

8 50615152

9 50615062

10 50615072

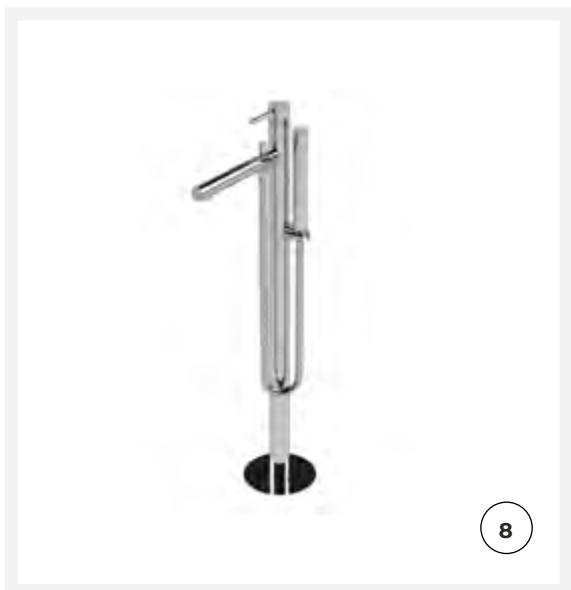

8



9



10

# CAYENNE



16



17



11 50615172

12 50625572

13 50625772

14 50615472

15 50615672

16 55173022

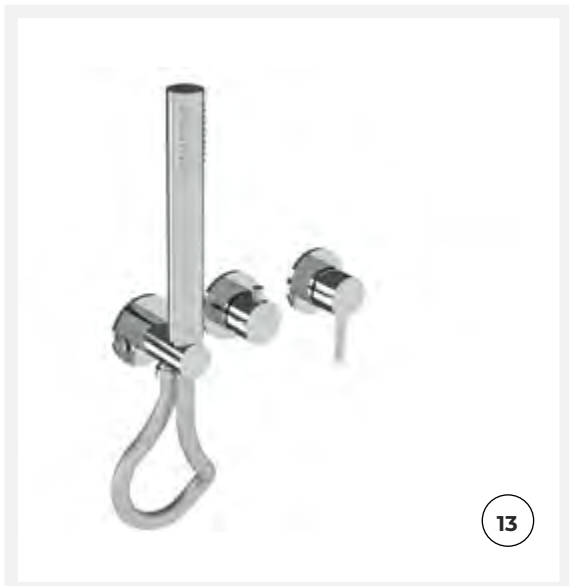
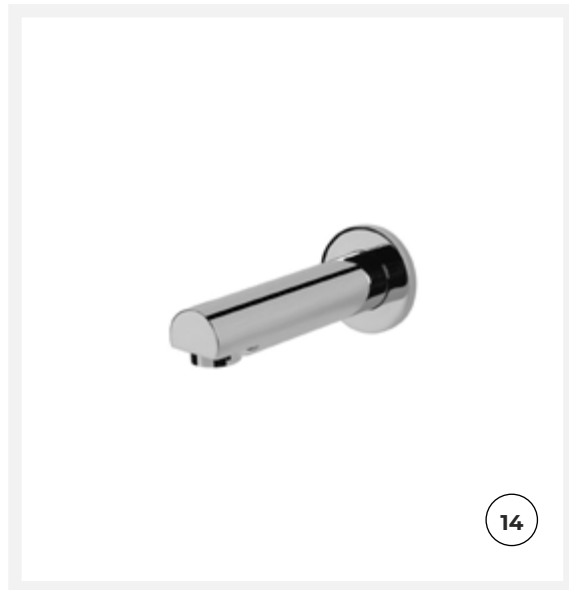
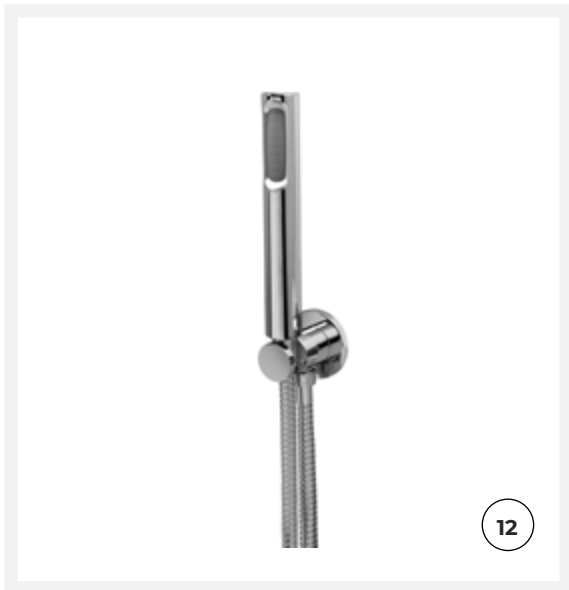

# ASSI



4



1



5



2



6

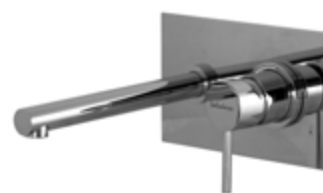

3





7

1 50625022

2 50625122

3 50625222

4 50625522

5 50625042

6 50625052

7 50615152

8 50625062

9 50625072

10 50625172

11 50625572



8



11

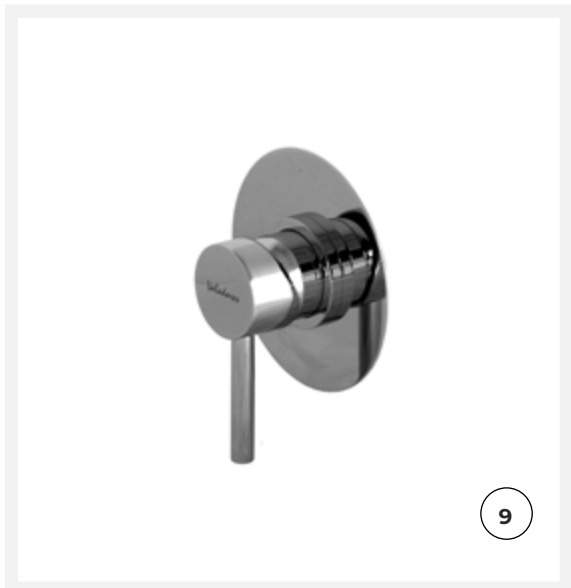

9



10

# ASSI

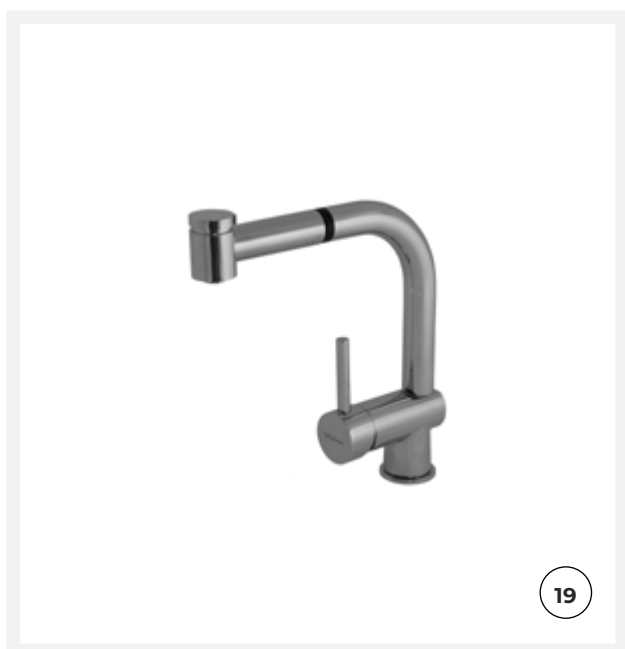
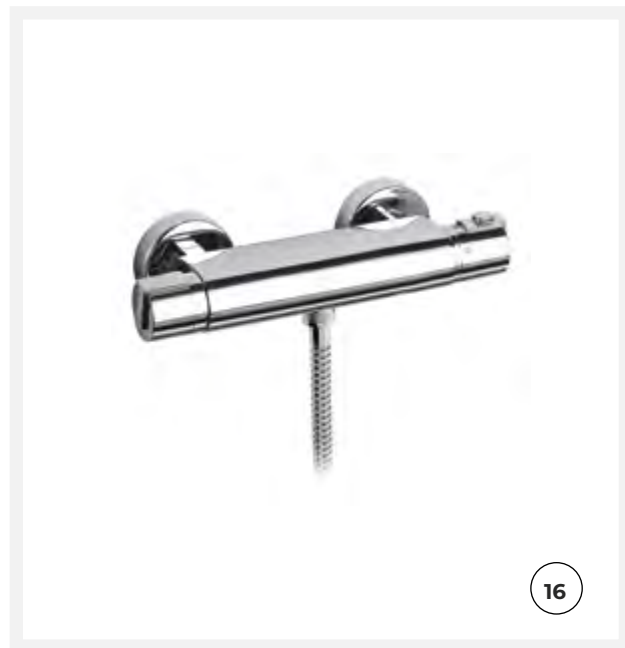
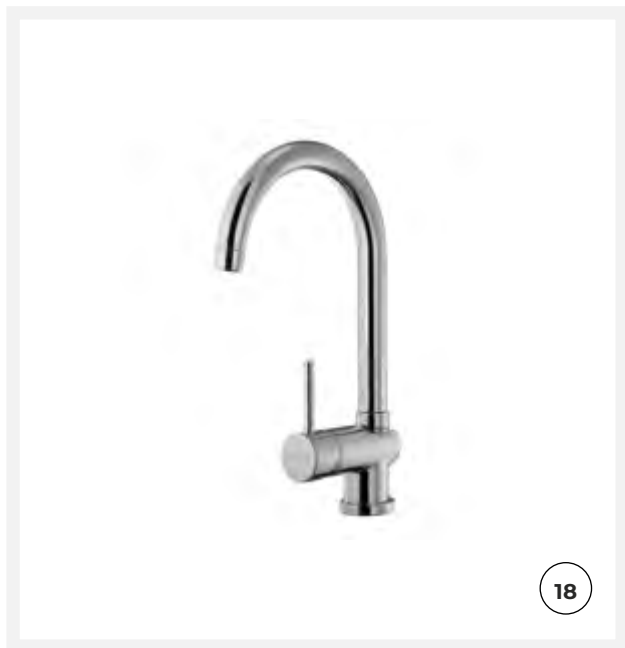

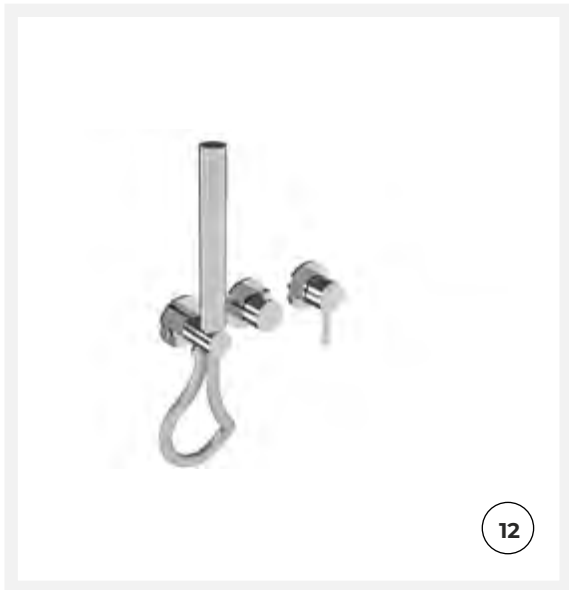

12

12 50625772

13 50615472

14 50615672

15 50625552

16 50601202

17 50601302

18 50625472

19 50625482



13



14

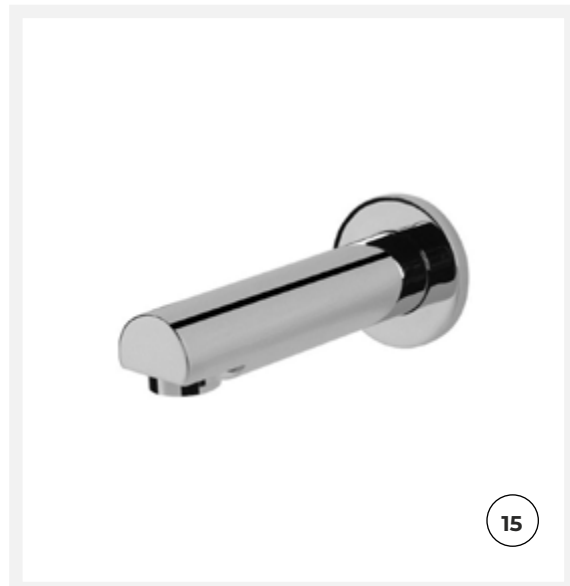

15

# SENSOR



1



2

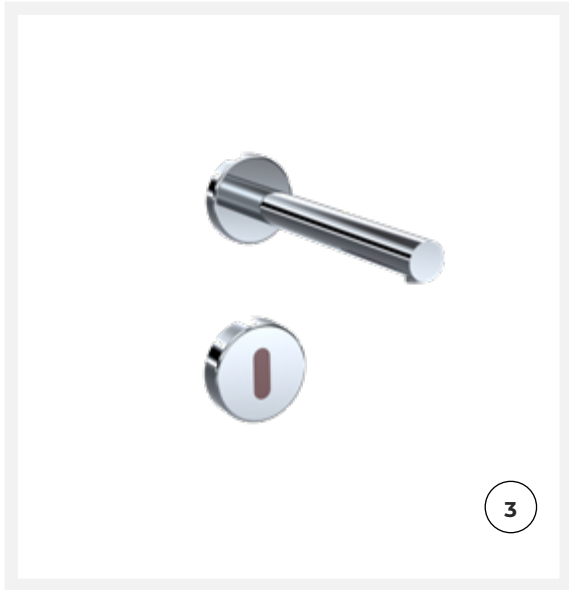

3

1 50602022

2 50602032

3 50602042

4 50602052

5 50602062



4

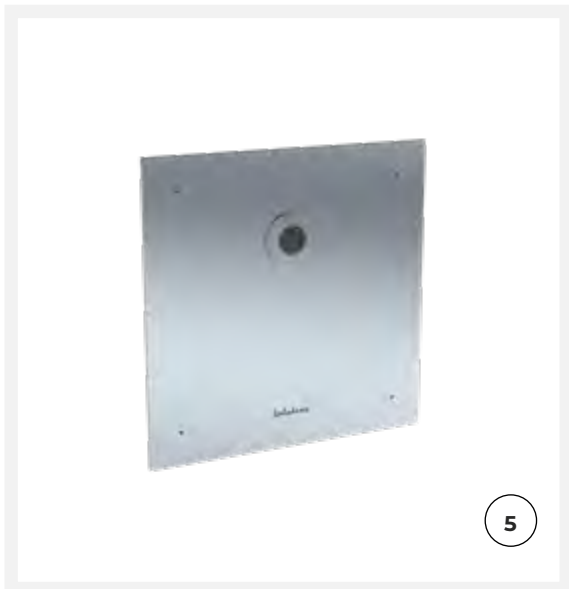

5

# TEMPORIZADAS

temporizados | timer taps | temporisés



4



1



5



2



6



3



1 50682022

2 50667112

3 50609512

4 50609012

5 50609612

6 50609712

7 50609072

8 50667092

9 50609172

10 50609002

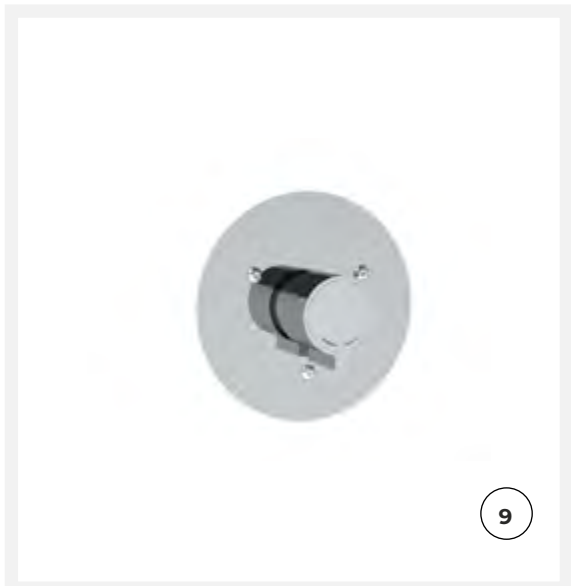
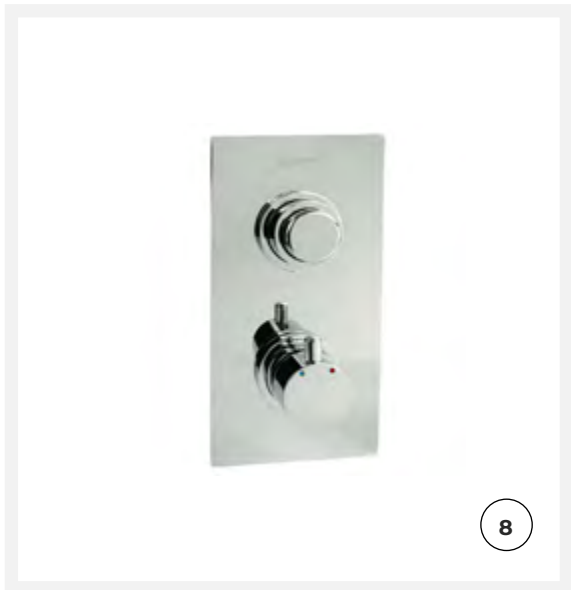

# TEMPORIZADAS

temporizados | timmer taps | temporisés



13



11



14



12



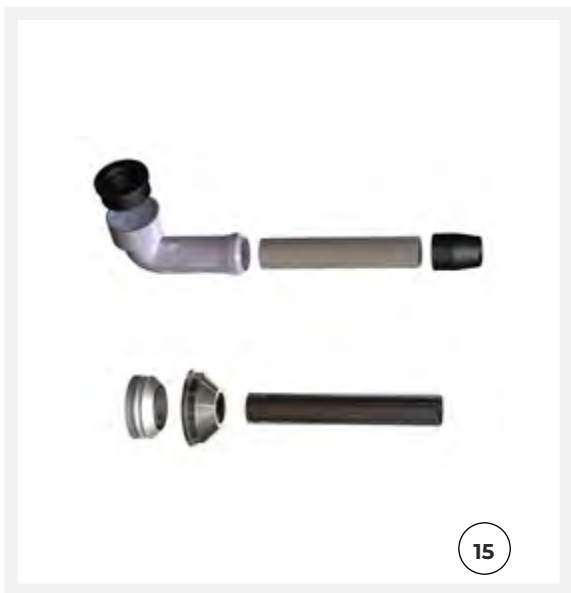

15

---

11 50609092

12 50609192

13 50609292

14 50609182

15 55067010

---

16 50609082

17 50609282

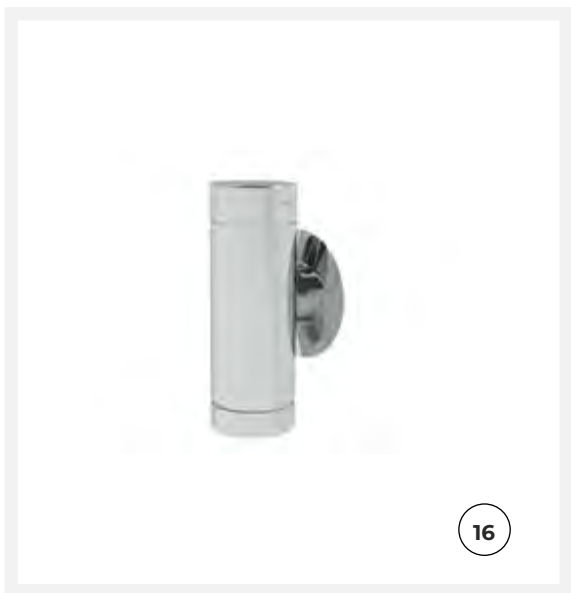

16

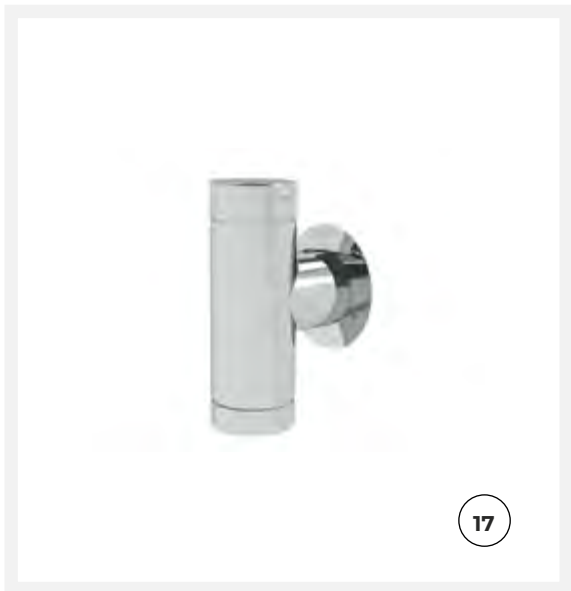

17

## MISTURADORAS DE DUCHE C/ COLUNA

grifos de ducha c/ columna | shower mixers w/ column

robinet de douche avec colonne

3



2



---

1 50680312  
50680512

2 50680322  
50680822

3 50680612  
50680712

4 50680622  
50680922



ACESSÓRIOS CERÂMICOS



ACCESORIOS CERÁMICA



CERAMIC ACCESSORIES



ACCESSOIRES CÉRAMIQUE





# BLEND

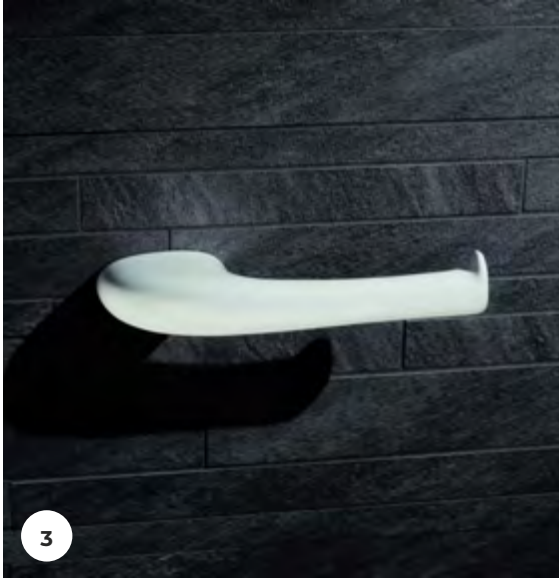
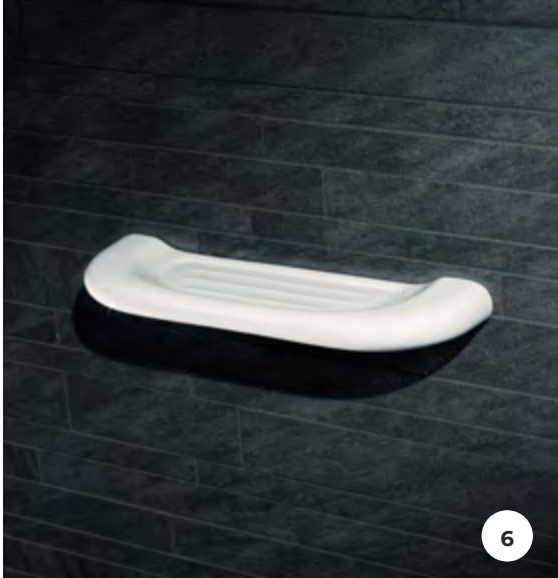
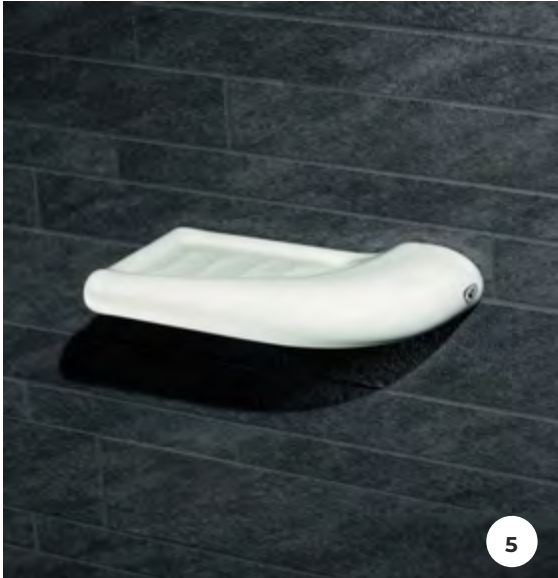
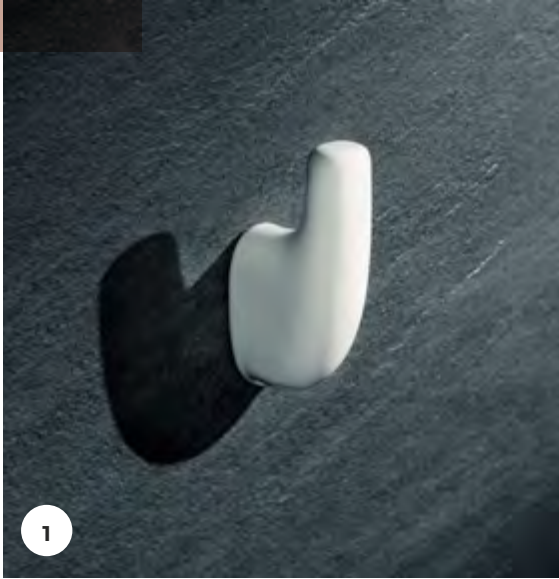
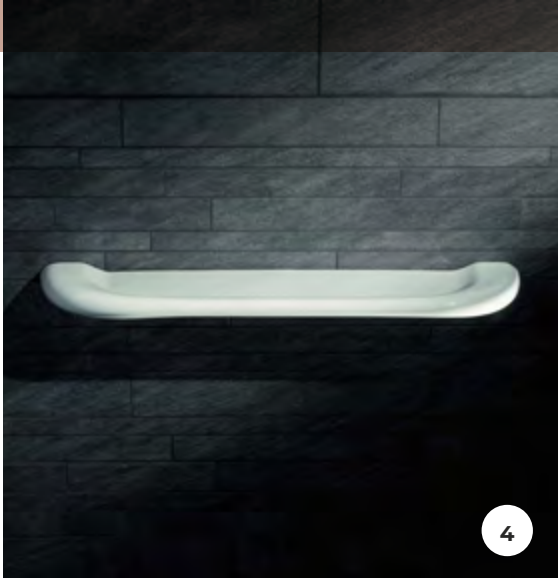

---

1 24001002

2 24100002  
55020005

3 24200002

4 24350002

5 24400002

---

6 24401002

7 24530002

8 24540002

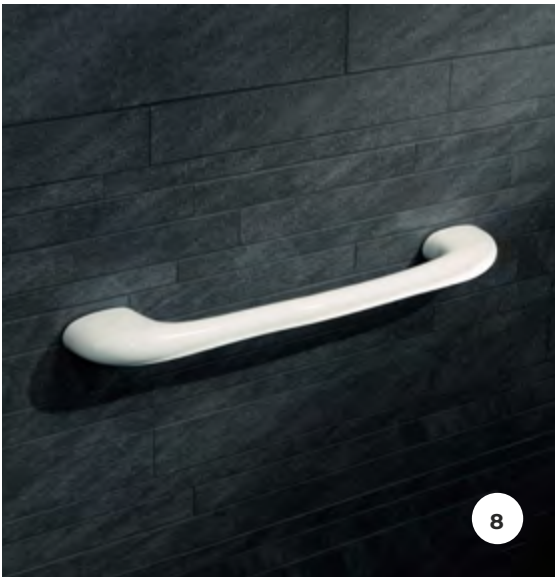
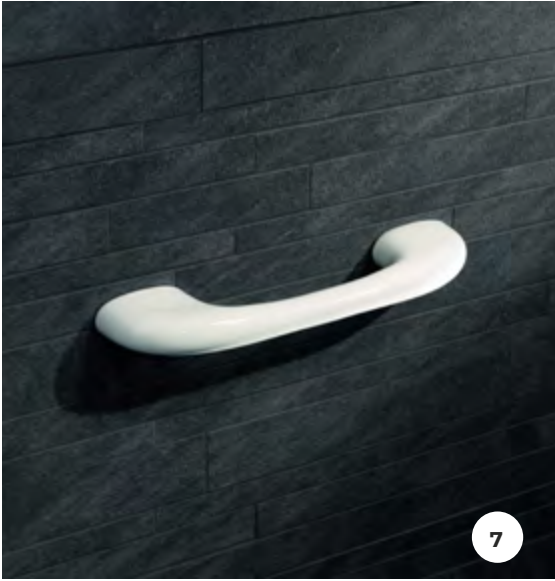

# NEOCLÁSSICA

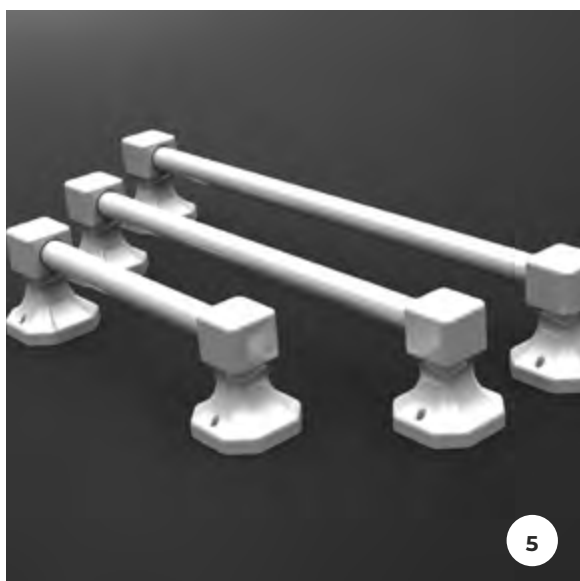



---

1 26001002

2 26100002  
55020005

3 26400002

4 26200002

5 26500002  
22630002  
22640002  
22650002  
22660002

---

6 26404002



# ALFA

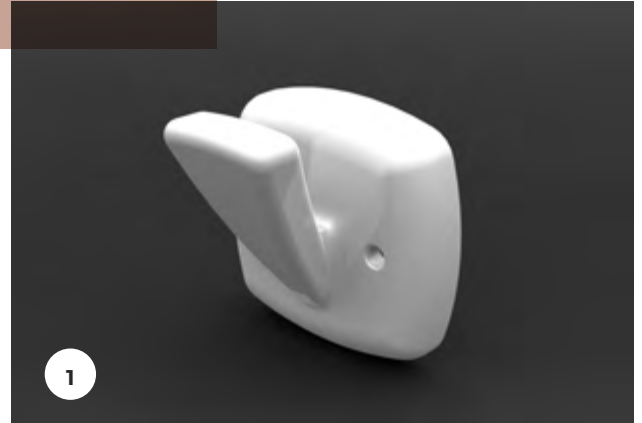

---

1 22001002

2 22100002  
55020005

3 22200002

4 22360002

---

5 22400002

6 22401002

7 22630002  
22640002  
22650002  
22660002

8 24540002

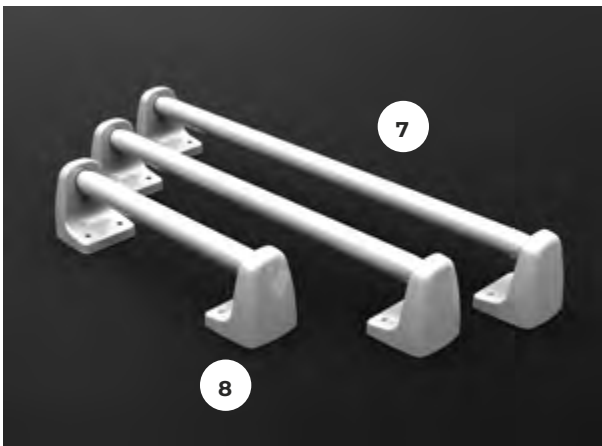

# Condições Gerais de Venda

## INTRODUÇÃO

Todas as relações comerciais entre a ARCH, SA e os seus Clientes são reguladas pelas seguintes “condições gerais de Venda” que conjuntamente com as “condições gerais de Pagamento” se consideram integralmente aceites pelo comprador no acto da encomenda.

### 1. Catálogos, ofertas e Encomendas

1.1 Todas as indicações e características constantes do material publicitário e informativo estão sujeitas às tolerâncias definidas pelas normas de regulamentação interna de e acordo com o normativo do sector.

1.2 Qualquer encomenda realizada à ARCH,SA deverá ser realizada em formato escrito, com devida identificação do Cliente, data e descrição técnica suportada nas nossas referências de artigo.

1.3 Todas as encomendas serão, para todos os efeitos, passíveis de confirmação por escrito por parte do Cliente.

1.4 Qualquer condição estipulada pelo Cliente nos seus pedidos e que não esteja em conformidade com as presentes “condições gerais de Venda” bem como “condições gerais de Pagamento” serão consideradas sem efeito, com posterior confirmação escrita, pela ARCH, SA.

### 2. Suspensão das Encomendas

2.1 A ARCH, SA reserva-se o direito de suspender a execução de qualquer encomenda nos seguintes casos:

- Quando o Cliente não tiver dado cumprimento parcial ou total a contratos anteriores;
- Quando por parte do Cliente se verificar recusa na recepção de encomendas após carga e expedição conforme prévia encomenda,
- Sempre que se verifique conduta indevida do Cliente em prejuízo da ARCH, SA.

### 3. Entregas

3.1 Os prazos de entrega são acordados entre a ARCH, SA e o Cliente no decurso da encomenda. Se nada for formalmente estipulado entre as partes, o prazo de referência para entrega será de 30 dias úteis. Sempre que não for possível garantir um prazo acordado, a ARCH, SA compromete-se a avisar o Cliente e a combinar um novo prazo.

3.2 Toda e qualquer encomenda poderá ser executada por entregas parciais.

3.3 Os artigos e mercadorias consideram-se entregues ao Cliente no momento da carga do meio de transporte deste e a respectiva guia de remessa assinada pelo operador do transporte quando este é da responsabilidade do Cliente. Nestes casos não serão aceites reclamações posteriores por faltas ou dano em mercadoria entregue.

3.4 Sempre que a mercadoria é entregue em transporte da responsabilidade da ARCH, SA, esta considera-se entregue quando da validação de recepção de mercadoria no destinatário.

3.5 O acto de recepção da mercadoria por parte do Cliente implica a confirmação do conteúdo e conformidade da mesma de acordo com encomenda efectuada e/ou com documentos comprovativos

de transporte. Qualquer anomalia deverá ser registada em Guia de remessa da ARCH, SA bem como na Guia de transporte.

3.6 Caso não seja possível verificar mercadoria no momento da entrega, o Cliente deverá assinalar nas Guias de Remessa e Transporte a referência “Sujeito a conferência”. Qualquer anomalia verificada deverá ser comunicada por escrito pelo Cliente aos nossos serviços comerciais em tempo útil e nunca superior a 5 dias úteis à data da recepção da mercadoria.

3.7 A ARCH, SA poderá recusar-se a efectuar o transporte de mercadoria sempre que :

- O local de destino não seja o armazém do Cliente ou local definido no momento da encomenda.
- O volume da encomenda não o justifique
- Sempre que houver recusa de recepção de mercadoria sem motivos imputáveis à ARCH,SA., sendo nesse caso debitado ao Cliente o valor relativo ao transporte e a custos adicionais decorrentes dessa condição.
- A ARCH, SA reserva-se o direito de considerar sem efeito toda a encomenda que aguarde mais de 30 dias após sua execução nas nossas instalações, sem que o Cliente proceda ao seu levantamento.

### 4. Preços

4.1 Os preços praticados são os constantes da tabela de preços da ARCH, SA em vigor no momento da expedição.

4.2 A Tabela de preços poderá ser alterada sem qualquer aviso prévio.

4.3 Em caso de publicação e divulgação de nova Tabela de Preços e no prazo de 8 dias úteis seguintes à sua divulgação, o Cliente poderá anular, por escrito, qualquer encomenda ainda não executada ou expedida pela ARCH, SA.

4.4 Consideram-se aceites pelos Clientes os preços constantes da nova tabela para as encomendas em curso e que não tenham sido objecto de anulação.

4.5 Os preços constantes da Tabela de Preços serão sempre líquidos de impostos em vigor, os quais serão devidamente discriminados em documentos de facturação.

4.6 Os preços constantes da Tabela de Preços serão acrescidos de despesas efectuadas com expedição e transporte da mercadoria e / ou embalagem especial quando solicitado pelo Cliente e aceite pela ARCH, SA.

### 5. Pagamentos

5.1 O pagamento das facturas rege-se pelas “Condições Gerais de Pagamento” da ARCH, SA em vigor à data da expedição.

5.2 Se o Cliente se constituir em mora, a ARCH, SA reserva-se o direito de suspender a execução de encomendas em curso de processamento ou recebidas entretanto.

5.3 Sempre que a ARCH, SA tomar conhecimento de factos e circunstâncias que que originem fundado receio de incumprimento de obrigações por parte do Cliente, poderá suspender o processamento e entrega de encomendas efectuadas, salvo mediante garantias fundamentadas do Cliente que honrará os seus compromissos de pagamento em prazo acordado e aceite pela ARCH,SA

### 6. Garantia de Artigos Cerâmicos

6.1 A ARCH , SA dá garantia de 20 anos sobre todos os artigos cerâmicos Sanitários da sua concepção e produção, considerando a data de venda.

6.2 Os artigos que durante este período apresentem algum problema técnico ou de qualidade evidente e da responsabilidade da ARCH,SA , serão substituídos sem custos para o Cliente.

6.3 Para que a garantia seja activada, é imprescindível que os defeitos sejam comunicados por escrito aos serviços comerciais da ARCH, SA , acompanhados dos respectivos documentos comprovativos da venda e entrega por parte da ARCH,SA para devida comprovação de origem e data de entrega.

6.4 A aceitação da reclamação será condicionada por validação técnica dos nossos serviços técnicos, para despistagem de causas não cobertas pela garantia aqui descrita, como uso indevido, deficiente instalação ou manutenção, danos de transporte, manipulações, reparações ou alterações efectuadas por terceiros, sem o nosso consentimento escrito.

6.5 A garantia sobre produtos cerâmicos por nós concebidos e produzidos, exclui toda e qualquer responsabilidade decorrente de consequências relativas a incompatibilidade técnica de instalações do Cliente, más condições de operação da instalação, assim como condições indevidas de armazenamento ou manuseamento e não aceitaremos nenhuma reclamação por despesas com as mesmas, assim como responsabilidades legais por danos ou prejuízos.

6.6 O material reclamado será repostado pela ARCH,SA no mais curto espaço de tempo e de acordo com a disponibilidade de material igual ao reclamado.

### **7. Garantia de componentes não cerâmicos**

7.1 A ARCH , SA garante por período de 2 anos, desde a data de compra (comprovada),os produtos não cerâmicos por si comercializados e a seguir discriminados:

- Componentes dos mecanismos de descarga: Válvulas, vedantes, tanques.
- Componentes das Bacias : Sistemas de fixação, tampos, tubos de descarga
- Componentes dos Bidés : Torneiras, válvulas, tampo, e fixação
- Componentes de Lavatórios: Torneiras, válvulas, fixações.

7.2 Para que a presente garantia seja válida, os equipamentos deverão ser instalados de acordo com as nossas instruções técnicas de montagem e operação.

7.3 A presente garantia não cobre reclamações que resultem de uso indevido, desgaste prematuro por condições de utilização não destinadas à sua configuração ou funcionalidade, alterações realizadas por terceiros, manutenção negligente, desadequação às instalações do Cliente.

### **8. Reclamações**

8.1 Todas as reclamações relacionadas com a entrega de mercadorias (quebras, erros quantidade, faltas, etc) terão de ser efectuadas por escrito para os nossos serviços comerciais num período máximo de 5 dias úteis a contar da data (confirmada) de recepção.

8.2 Qualquer reclamação de discordância de preços ou descontos praticados na factura deverá ser efectuada por escrito para serviços comerciais até 15 dias após a data de recepção da mesma.

8.3 Qualquer reclamação técnica ou de qualidade dos nossos produtos e mercadorias, deverá ser comunicada por escrito para os nossos serviços comerciais, com a descrição do problema, peças e quantificação de artigos envolvidos. O Cliente deverá garantir a guarda do material defeituoso até à sua substituição , sem custos para o Cliente, após devido

processamento e aceitação de reclamação por parte da ARCH, SA.

8.4 A ARCH ,SA procederá de forma a assegurar uma resposta em tempo útil à reclamação de cada Cliente , cujo tempo de resolução

estará condicionado pelo processo de análise de causas e a necessária clarificação de responsabilidades.

### **9. Devoluções**

9.1 A ARCH ,SA não aceitará qualquer devolução sem a prévia validação escrita do seu departamento Comercial e após devida fundamentação.

9.2 Não serão aceites devoluções de artigos sanitários em modelos e cores que não façam, à data, parte da gama comercializada.

9.3 Mercadorias e componentes não existentes no portfólio comercializado à data ou com tempo de venda superior à garantia comercial.

### **10. Litígios**

10.1 O foro competente para dirimir qualquer litígio emergente das transacções comerciais reguladas pelas presentes "condições gerais de Venda" é o da comarca de Vila Nova de Gaia.

10.2 De acordo com a lei n.º 144/2015 de 8 de Setembro , em caso de litígio o cliente pode recorrer ao Centro de Informação de Consumo e Arbitragem do Porto para resolução alternativa de litígios de consumo.

### **CONDIÇÕES GERAIS DE PAGAMENTO**

1. Os fornecimentos a novos Clientes terão de ser liquidados por cheque ou numerário contra entrega da mercadoria. A abertura de crédito só poderá ser concedida após aprovação da Direcção Financeira e da Direcção Comercial da ARCH,SA.

2. Uma vez acordada a concessão de crédito e estabelecido o plafond respectivo, todas as facturas terão de ser liquidadas a um prazo máximo de 60 dias após a data de emissão.

3. No início de cada mês será emitido um resumo das facturas relativas ao mês anterior.

4. Serão concedidos descontos financeiros de acordo com as condições definidas em contrato com o Cliente ou aplicando regra geral de 2% de desconto financeiro a pronto pagamento.

5. A ARCH, SA reserva-se o direito de debitar juros compensatórios sempre que não se verifique o cumprimento das condições de pagamento aqui estabelecidas. Em caso algum será aceite como justificação para o não pagamento duma factura, a existência de situações pendentes relativas a outros fornecimentos.

6. Haverá suspensão de fornecimentos sempre que ocorra uma das seguintes situações:

6.1 Pagamento de mercadorias seja efectuado com cheque sem provisão

6.2 Existam facturas vencidas por liquidar sem uma devida justificação

6.3 O plafond de crédito concedido tenha sido ultrapassado.

7. A nenhum Cliente com crédito suspenso será satisfeito qualquer encomenda, mesmo que o novo fornecimento seja contra pronto pagamento.

8. Em caso algum a ARCH,SA aceitará letras como forma de pagamento, mesmo que os encargos fiquem por conta do Cliente.

### **CONDIÇÕES GERAIS**

1. A todos os preços da Tabela de Preços acresce o valor de I.V.A. à taxa em vigor.

2. Os preços da Tabela de Preços podem ser alterados sem aviso prévio.

3. As características e dimensões dos artigos constantes da Tabela de Preços estão sujeitas às 4. tolerâncias técnicas regulamentadas em normas do sector de actividade.

4. Reserva-se o direito de eliminar e alterar referências a artigos e mercadorias comercializadas e constantes da Tabela de Preços.

# Condiciones Generales de Venta

## INTRODUCCIÓN

Todas las relaciones comerciales entre ARCH S.A. y sus clientes son reguladas por las "condiciones generales de venta" que junto las "condiciones generales de pago" se consideran aceptadas integralmente por el comprador en el momento de la compra.

### 1. Catálogos, ofertas y pedidos

1.1 Todas las indicaciones y características que constan en la publicidad y material informativo están sujetas a las tolerancias establecidas por las reglas internas en conformidad con las normas del sector.

1.2 Cualquier pedido realizado a ARCH S.A. se tendrá que hacer por escrito, con la debida identificación del cliente, fecha y descripción técnica conforme las referencias del producto.

1.3 Todos los pedidos serán para los debidos efectos sujetos a confirmación por escrito de la parte del cliente.

1.4 Cualquier condición estipulada por el cliente en sus pedidos y que no esté conforme con las presentes "condiciones de venta" así como en las "condiciones generales de pago" se considerarán sin efecto y serán confirmadas por escrito por ARCH S.A. con posterioridad.

### 2. Cancelación de pedidos

2.1 ARCH, SA se reserva el derecho de cancelar un pedido en los siguientes casos:

- Cuando hubiera incumplimiento parcial o total de contratos anteriores.
- Cuando el cliente se niega a recibir la mercancía después de la expedición de la misma y mediante previa confirmación del pedido.
- Siempre que se constate un comportamiento indebido en detrimento de ARCH S.A.

### 3. Entregas

3.1 Los plazos de entrega se definen entre ARCH, SA y el cliente durante el transcurso del pedido. Si no hubiera nada estipulado el plazo de referencia para la entrega es de 30 días laborables. Si no fuese posible garantizar un plazo estipulado, ARCH S.A. se compromete a avisar al cliente con un nuevo plazo.

3.2 Todos los pedidos se podrán satisfacer mediante entregas parciales.

3.3 Todos los productos y mercancías que se hayan recogido a través del transporte del cliente se considerarán como entregados en el momento de su carga mediante la firma del albarán por el correspondiente conductor siempre y cuando la responsabilidad del transporte recaiga en el cliente. En estos casos no se aceptarán reclamaciones a posteriori sea por faltas o daños.

3.4 Cuando la responsabilidad del transporte recaiga en ARCH S.A. la mercancía se considerará como entregada en el momento de la firma del albarán en el destino acordado.

3.5 El acto de recepción de la mercancía por parte del cliente implica la confirmación de su contenido y consecuente conformidad de acuerdo con el pedido efectuado y/o con los documentos del transporte que lo comprueben. Cualquier anomalía se deberá registrar en el albarán de ARCH S.A. y en el respectivo documento de transporte.

3.6 En el caso que no se pueda comprobar la mercancía en el acto de entrega, el cliente tendrá que hacer referencia en el albarán y documento de transporte el siguiente comentario " sujeto a confirmación".

Cualquier anomalía deberá ser comunicada por el cliente por escrito para nuestros servicios comerciales en tiempo útil y nunca superior a 5 días laborables después de la recepción de la mercancía.

3.7 ARCH, SA se puede negar a realizar un transporte de la mercancía en las siguientes circunstancias:

- Cuando el destino no sea el almacén del cliente o el local de entrega estipulado en el pedido.
- Cuando la cantidad pedida no lo justifique.
- Si el cliente se recusa a descargar la mercancía por motivos no imputables a ARCH S.A. en cuyo caso se procederá al cargo del transporte y demás costes adicionales que puedan surgir como consecuencia de ese acto.
- ARCH, SA se reserva el derecho de considerar sin efecto todo pedido que quede en espera más de 30 días después de su disponibilidad sin que el cliente proceda a la respectiva recogida

### 4. Precios

4.1 Los precios practicados son los que constan en la tarifa de ARCH, S.A. en vigor en el momento de la expedición.

4.2 Se podrá alterar la tarifa sin previo aviso.

4.3 El cliente podrá anular en un plazo de 8 días laborables posteriores a la publicación de la nueva tarifa, cualquier pedido en curso no efectuado o expedido por ARCH S.A

4.4 Los pedidos en curso que no hayan sido anulados después del tiempo transcurrido para ese efecto tendrán como base los nuevos precios.

4.5 Los precios que constan en la tarifa serán siempre antes de los impuestos en vigor y los cuales aparecerán en las respectivas facturas.

4.6 Los precios de tarifa podrán sufrir un aumento según eventuales costes de expedición, transporte y/o embalaje especial que sean solicitados por el cliente y aceptados por ARCH S.A.

### 5. Pagos

5.1 El pago de facturas se rige por las "condiciones Generales de Pago" de ARCH S.A. en vigor a la fecha de expedición.

5.2 Si el Cliente entra en mora, ARCH ,SA se reserva el derecho de suspender los pedidos pendientes de servicio.

5.3 Siempre que ARCH S.A. tome conocimiento de hechos y circunstancias que puedan originar un incumplimiento por parte del cliente, esta podrá suspender los pedidos en curso salvo mediante la presentación de garantías de pago fidedignas por parte del cliente y que sean previamente aprobadas por ARCH S.A.

### 6. Garantía de Productos cerámicos

6.1 ARCH ,S.A ofrece una garantía de 20 años sobre todos los artículos cerámicos Sanitarios de su autoría a partir de la fecha de venta.

6.2 Los artículos que durante ese período presenten algún problema técnico o de calidad evidente serán substituidos sin cualquier coste para el cliente y desde que sea responsabilidad de ARCH S.A.

6.3 Es imprescindible que los defectos sean comunicados por escrito a los servicios comerciales de ARCH S.A. para que se produzca la

activación de la mencionada garantía. Esa comunicación deberá ir acompañada de los documentos comprobantes de la venta y entrega por ARCH S.A. para efectos de verificación de origen y fecha de entrega.

6.4 La aceptación de la reclamación estará condicionada por la validación técnica de nuestros servicios técnicos para un apuramiento de eventuales causas que puedan estar fuera de la cobertura de la garantía como el uso indebido y deficiente de la instalación o mantenimiento, desperfectos en el transporte, manipulaciones, reparaciones o alteraciones efectuadas por terceros sin un previo acuerdo o consentimiento por escrito.

6.5 La garantía sobre los productos cerámicos concebidos y producidos por ARCH S.A. excluye toda y cualquier responsabilidad que transcurra de consecuencias relativas a la incompatibilidad técnica de las instalaciones del cliente, malas condiciones de operatividad de las instalaciones, así como condiciones indebidas de almacenaje o manejo y no se aceptará ninguna reclamación por gastos con las mismas así como responsabilidades por daños y perjuicios.

6.6 Se repondrá el material reclamado en el espacio de tiempo más breve posible y de acuerdo con la disponibilidad del material igual al reclamado.

### **7. Garantía de componentes no cerámicos**

7.1 ARCH, SA garantiza por un período de 2 años, desde la fecha de compra (comprobada), los productos no cerámicos que se siguen:

- Componentes de los mecanismos de descarga: Válvulas, aislantes, tanques.
- Componentes de los inodoros: Sistemas de fijación, tapas, tubos de descarga
- Componentes de los Bidés: Grifos, válvulas, tapas, y fijación
- Componentes de los lavabos: Grifos, válvulas, tapas, y fijaciones.

7.2 Para que la presente garantía sea válida, los equipos deberán ser instalados de acuerdo con nuestras instrucciones técnicas de montaje y operación.

7.3 La presente garantía no cubre reclamaciones que resulten del uso indebido, desgaste prematuro por condiciones de utilización no destinadas a su configuración o funcionalidad, alteraciones realizadas por terceros, mantenimiento negligente o inadaptación a las instalaciones del cliente.

### **8. Reclamaciones**

8.1 Todas las reclamaciones relacionadas con la entrega de mercancías (quebras, errores de cantidad, faltas etc.) se tendrán que efectuar por escrito a nuestros servicios comerciales en un tiempo máximo de 5 días laborables a partir de la fecha (comprobada) de entrega.

8.2 Cualquier reclamación sobre la disputa de precios o descuentos constantes en la factura se tendrá que efectuar por escrito hasta 15 días después de la recepción de la misma.

8.3 Se deberá comunicar por escrito para nuestros servicios comerciales cualquier reclamación técnica o de calidad de nuestros productos y mercancías con la descripción del problema, piezas y cuantificación de los artículos en cuestión. El cliente deberá garantizar el almacenaje del material defectuoso hasta su substitución, sin costes para el, y solamente después de la aceptación previa por parte de ARCH S.A de la respectiva reclamación.

8.4 A ARCH, S.A siempre procederá de manera a dar una respuesta a la reclamación de cada cliente en tiempo útil y cuya solución dependa de las causas y el apuramiento de responsabilidades.

### **9. Devoluciones**

9.1 ARCH, S.A. no aceptará cualquier devolución sin la aceptación previa por escrito del departamento comercial y mediante la debida

fundamentación.

9.2 No se aceptarán devoluciones de artículos sanitarios cuyos modelos y colores no hagan parte de la gama actual en comercialización.

9.3 No se aceptarán mercancías y componentes que no existan en la gama comercializada presentemente o con tiempo de venta superior a la garantía comercial.

### **10. Litigios**

10.1 El fuero competente para dirimir cualquier litigio resultante de las transacciones comerciales reglamentadas por las presentes "condiciones generales de venta" es el de la comarca de Vila Nova de Gaia.

10.2 De acuerdo con la Ley n° 144/2015 del 8 de Septiembre, em caso de litigio el cliente puede recurrir al " Centro de Informação de Consumo e Arbitragem" de Porto para una resolución alternativa de litigios al consumo.

### **CONDICIONES GENERALES DE PAGO**

1. Los suministros de nuevos clientes se tendrán que pagar mediante cheque o en efectivo al entregar la mercancía. La apertura de crédito solamente se podrá efectuar mediante la aprobación previa de la dirección Financiera y Comercial de ARCH S.A.

2. Una vez que se aprueba la apertura de crédito y el respectivo limite, todas las facturas tendrán que ser liquidadas pasados 60 días de la fecha de emisión de las mismas.

3. Al inicio de cada mes se emitirá un resumen de las facturas del mes anterior.

4. Los descuentos financieros se concederán de acuerdo con las condiciones especificadas en el contrato de cada cliente o aplicando la regla general del 2% de descuento a pronto pago.

5. ARCH, SA se reserva el derecho a cobrar intereses de demora siempre y cuando no se verifiquen las condiciones de pago aqui establecidas. En ninguna circunstancia se aceptará como justificación del impago la existencia de situaciones pendientes relativas a otros suministros.

6. Habrá suspensión de suministros siempre que ocurra una de las siguientes situaciones:

6.1 Pago de mercancías con un cheque sin fondo.

6.2 Existencia de facturas en atraso sin la debida justificación.

6.3 Alcanzar el Límite de crédito.

7. No habrá nuevo suministro una vez que el crédito se encuentre anulado aún cuando el nuevo suministro sea a pronto pago.

8. En ningún caso se aceptarán letras de cambio como forma de pago aun cuando los gastos corran por cuenta del cliente.

### **CONDICIONES GENERALES**

1. Los precios en la tarifa no incluyen el IVA.

2. Los precios en la tarifa pueden sufrir alteraciones sin previo aviso.

3. Las características y dimensiones de los artículos que figuran en la tarifa se someterán a las tolerancias técnicas especificadas en las respectivas normas del sector.

4. Se reserva el derecho de eliminar o alterar referencias a artículos y mercancías constantes en la tarifa.

# General Conditions of Sale

## INTRODUCTION

All commercial relations between ARCH, SA and its Clients are ruled by the following "General Terms of Sale" which, together with the "General Terms of Payment" are deemed to have been fully accepted by the purchaser at the time its order is made.

### 1. Catalogues, offers and orders

1.1 All indications and characteristics stated in our advertising material are subject to the tolerances defined in the Quality Assurance System in accordance with the standards in force for the sector.

1.2 Any order to ARCH, SA shall be made in writing by way of a duly numbered requisition on company headed paper, date and technical description on our catalogue references.

1.3 To all intents and purposes, all orders are subject to acceptance in writing.

1.4 Any condition stipulated by the Client in its requests which does not conform to the present "General Terms of Sale" or to the "General Terms of Payment" shall be deemed null and void, unless subsequently confirmed in writing by ARCH, SA.

### 2. Suspension of orders

2.1 ARCH, SA reserves the right to suspend the execution of any order in the following cases:

- When the Customer has not given partial or full compliance with previous contracts;
- When by the Customer to check refuses to receive their orders after loading and dispatch as prior order,
- Where there is Customer misconduct to the detriment of ARCH, SA.

### 3. Deliveries

3.1 The delivery dates are agreed upon between ARCH, SA and its Clients. Should nothing be formally stipulated by both parties, the delivery date to be assumed shall be of 30 days. Whenever this cannot be met, ARCH, SA undertakes to notify the Client and agree upon a new date.

3.2 Any order may be carried out through partial deliveries.

3.3 The goods are deemed to have been delivered to the Client as soon as their loading onto the truck has been completed at ARCH, SA warehouse and the respective Delivery Slip has been signed by the driver, with transport being wholly the responsibility of the Client meaning that, in such cases, no complaints shall be accepted owing to the breakage of material or goods missing.

3.4 Whenever transport is carried out in transport chartered by ARCH, SA the goods shall be deemed to have been delivered upon their receipt at the destiny.

3.5 The Client shall verify upon receipt whether the products correspond to those ordered by it. Any irregularity shall be registered on ARCH, SA Delivery Slip as well as on the Transporter Slip.

3.6 Should it not be possible to verify the goods upon delivery, the Client shall write on the corresponding Delivery Slips and on the Transporter Slip "Subject to Conferral". Any irregularity detected shall be communicated to our commercial services in writing within no more than 5 days

3.7 ARCH, SA may refuse to transport orders whenever:

- The place of destination is not the Client's warehouse or that agreed upon previously;
- The volume of the order does not so justify.
- Whenever there is a refusal to receive, for reasons not attributable to ARCH, SA, the Client shall be charged an amount corresponding to the value of transport.
- ARCH, SA reserves the right to deem null and void any order remaining over 30 days after it was made without the Client having collected it.

### 4. Prices

4.1 The prices charged are always those set out in the Price Table of ARCH, SA in force at the time of dispatch of the goods.

4.2 The Price Table may be altered without any prior notice.

4.3 Owing to the coming into force of the new Price Table of ARCH, SA, and within eight days after its disclosure, the Client may cancel, in writing, any order yet to be implemented or dispatched by ARCH, SA.

4.4 In case of projects in study with deliveries scheduled for the coming year, the proposed prices shall have the validity of the budget even if some change in the price list occurs in that period.

4.5 The prices set out in the table shall be deemed to have been accepted by the Clients whenever their orders have not been subject to cancellation in accordance to the point.

4.6 The prices stated in the Table are always net of the taxes in force which shall always be itemised on the invoices.

4.7 Any expenses defrayed on dispatching goods in special packaging shall accrue to the prices stated in this price list whenever said packaging is requested by the Client and accepted by ARCH, SA.

### 5. Payments

5.1 The payment of invoices is subject to the "General Terms of Payment" of ARCH, SA in force as at the date of dispatch.

5.2 If the Client is late in making payment, ARCH, SA reserves the right to suspend the implementation and dispatch of any orders in portfolio.

5.3 Whenever ARCH, SA learns of any facts and circumstances which cause well-founded fears of breaches in compliance with obligations by the Client, it may suspend the delivery of goods, unless the purchaser provides guarantees in a timeframe to be agreed upon.

### 6. Guarantee of ceramic components

6.1 ARCH, SA gives guarantee of 20 years from buying date to all ceramic products conceived and produced by them.

6.2 All the ceramic wares that during this period show any problem due to any material defect or manufacturing one will be replaced to the customer for free.

6.3 In order to activate the guarantee it is necessary that all defects are communicated immediately by written to ARCH, SA, together with invoice or other document issued by us proving the origin and delivery date of the product.

6.4 The acceptance of the claim shall be conditioned by our Quality Department to verify causes non covered by this guarantee such as



negligence, bad installation and/ or maintenance, transport damages, handling, repairs or intervention done by third parties without our Previous written permission.

6.5 The guarantee about ceramic products conceived and produced by ARCH, SA exclude all and any responsibility coming from technical incompatibility of Client premises, bad conditions of installing process, and also improper storage or handling conditions. ARCH, SA shall not accept any claim of expenses occurred from those referred situations as well as legal responsibility for damages or prejudices.

6.6 The claimed material will be replaced by ARCH, SA in the shortest period and according to the availability of such material.

### **7. Guarantee of non ceramic components**

7.1 A ARCH,SA grants 2 years guarantee from buying date (duly proved) on the bellow non-ceramic products:

- Discharge Mechanisms components: Valves, sealant system and plastic cisterns;
- WC components: Seats, fixation systems and discharge pipes;
- Bidet components: Taps, valves, seats and fixation systems;
- Washbasins components: Taps, valves and fixation systems.

7.2 This Guarantee comes in force always and when all the proceedings written on installation manual have been followed (if applicable).

7.3 The present guarantee does not cover claims occurring from the misuse, premature deterioration for usage conditions not designated to its configuration or functionality, changes done by third parties, negligent maintenance, inadequate to client's premises.

### **8. Claims**

8.1 As specified in 3.1 all claims related to the delivery of products (breaks, quantity errors, failures, etc) must be made in writing to Commercial Department within a period of 5 days from the date of receipt of the same.

8.2 Any claim owing to a disagreement over the prices or discounts made to the invoice shall be lodged in writing to Commercial Department within 15 days after receipt thereof.

8.3 Any technical or quality claim of our products must be communicated by written to our Commercial services with full description of the problem, pieces and quantification. The client must guarantee to keep the materials properly until its replacement after verification and acceptance of the claim by ARCH, SA.

8.4 ARCH, SA shall assure a reply in appropriate time to each Client claim, which resolution time shall be conditioned by the confirmation of responsibilities.

### **9. Returns**

9.1 ARCH, SA will not accept any return without the prior authorisation in writing of its Commercial Department.

9.2 Under no circumstances shall returns be accepted of sanitary ware in models or colours which do not, to date, form part of the current range

9.3 All products and components non existent in the catalogue to date or with selling date superior to commercial guarantee.

9.4 The charges with the return process of all the products shall be on

the Clients responsibility.

### **10. Disputes**

10.1 The competent venue for settling any litigation arising out of the commercial transactions regulated by the present "General Terms of Sale" is the District of Vila Nova de Gaia.

10.2 According to Law No. 144/2015 of September 8, in the event of litigation the customer may use the Consumer Information and Arbitration Center of PORTO for alternative resolution of consumer disputes

### **GENERAL TERMS OF PAYMENT**

1. Supplies to new Clients must be paid upon delivery of goods. Credit shall only be granted after approval of the Financial Management and the Commercial of ARCH, SA.

2. Once it has been agreed to grant credit and the respective limit has been established, all invoices must be settled within 60 days after the date of the respective issue.

3. At the start of each month a summary of invoices shall be issued relating to the previous month.

4. A prompt payment discount shall be granted (in cheque, cash or bank transfer) with order acceptance, or with payment in the delivery date, or by payment at loading date, or by financial discount with payment till 15 days after invoice date, according personalized conditions.

5. ARCH, SA has the right to cancel given discounts all the time the terms of payment previously established are not fulfilled.

6. Supplies shall be suspended in the event of any of the following situations:

6.1 The payment of the goods and/or costs has been made with a bouncing cheque;

6.2 There are documents due and unpaid without proper justification;

6.3 The credit plafond assigned has been exceeded.

7. Any Client whose credit has been suspended cannot make an order even if prompt payment is made

8. In any case, ARCH, SA shall accept bill of exchanges as payment, even with charges on client's account.

### **GENERAL CONDITIONS**

1. All prices in the price list are subject to vat at the legal rate in force.

2. Prices may be changed without prior notice.

3. The characteristics and measurements shown are subject to some technical tolerances, according to the norms of this activity sector.

4. We reserve the right to alter and/or eliminate products shown in this price list

5. The commercialisation of the aforementioned products is subject to the general terms of sale and payment set out in this price list.

# Conditions Générales de Vente

## Introduction

Toutes les relations entre ARCH, SA et ses clients seront régulées par les présentes conditions « générales de vente » qui, additionnées aux « conditions générales de paiement », sont considérées comme intégralement acceptées par l'acheteur lors de la commande.

## 1. Catalogues, offres et commandes

1.1 Toutes les indications et caractéristiques spécifiées sur les supports publicitaires et informatifs sont assujetties aux tolérances définies par les normes de régulation interne et en accord avec les normes du secteur.

1.2 Quelconque commande adressée à ARCH, SA devra être réalisée par écrit, avec l'information nécessaire étant : Identification du client, date et description technique associée à la référence de l'article.

1.3 Toutes les commandes seront, pour tous les effets, conditionnées à la confirmation par écrit du client.

1.4 Toute condition stipulée par le client lors de sa demande et qui soit pas en accord avec ces « conditions générales de vente » ainsi que les « conditions générales de paiement » seront considérées sans effet, avec postérieure confirmation écrite par Arch, SA

## 2. Suspension de commande

2.1 ARCH, SA se réserve le droit de suspendre l'exécution de quelconque commande dans les situations suivantes :

- Que le client n'a pas honoré partiellement ou totalement ses obligation sur un contrat antérieur
- Quand, de la part du client, il y aura un refus de réception de commande suivant la charge et expédition de cette commande
- Dans tout les cas ou il y aura une conduite inappropriée du client envers ARCH, SA

## 3. Livraison

3.1 Les délais de livraison sont accordés entre ARCH, SA et le Client au cours de la commande. Si rien n'est stipulé par aucune des parties, le délai de référence pour la livraison sera de 30 jours ouvrés. Dans le cas ou il ne serait pas possible garantir le délai accordé lors de la commande, ARCH, SA s'engage à prévenir le client et convenir d'une nouvelle date de livraison.

3.2 Toute commande pourra être exécutée pour des livraisons partielles.

3.3 Les articles sont considérés livrés au client au moment de la charge sur le moyen de transport du client et le bon de livraison signé par l'opérateur chargé de ce transport quand celui-ci est la responsabilité du client. Dans ce cas de figure, ne sera acceptée aucune réclamation postérieure pour manque ou casse des articles livrés.

3.4 Dans le cas ou la livraison est de la responsabilité de ARCH, SA les articles seront considérés livrés lors de la bonne réception et validation du destinataire.

3.5 La validation de réception de la marchandise par le client implique la vérification et la conformité du contenu en accord avec la commande passée et les documents de bon de livraison. Quelconque anomalie devra être spécifiée sur le bon de livraison.

3.6 Dans le cas ou il ne serait pas possible une vérification de la marchandise livrée au moment de la livraison, le client devra signer le

bon de livraison en ajoutant la mention « sous conditions de vérification ». Quelconque anomalie devra être communiquée par écrit par le client auprès de notre service commercial dans un délai maximum de 5 jours ouvrés à date de réception de la marchandise.

· ARCH, SA pourra refusé de transporté la marchandise dans les conditions suivantes :

· L'adresse de livraison ne correspond pas à l'entrepôt du client ou à l'adresse communiquée lors de la commande.

· Le volume de la commande ne justifie pas

· Dans le cas de refus de réception non imputable à ARCH, SA et étant ainsi facturé au client la valeur de ce transport et autres coûts associés

· ARCH, SA se réserve le droit de considéré sans effet toute commande qui serait en attente plus de 30 jours dans nos installations sans que le client procède à sa récupération.

## 4. Tarifs

4.1 Les tarifs pratiqués sont les prix indiqués sur le relevé tarifaire de ARCH, SA en vigueur au moment de l'expédition.

4.2 Le relevé tarifaire pourra subir des modifications sans aucun préavis

4.3 Dans le cas de la communication du nouveau relevé tarifaire et dans un délai de 8 jours, le client pourra annulé par écrit quelconque commande pas encore produite ou expédiée par ARCH, SA

4.4 Seront considérés comma acceptés par le client les tarifs indiqués par ce nouveau relevé tarifaire pour les commandes en cours et qui n'auront pas été annulées.

4.5 Les tarifs indiqués sur le relevé tarifaire seront toujours mentionnés hors taxes.

4.6 Les tarifs indiqués sur le relevé tarifaire pourront subir des hausses suivant les surcoûts engendrés par l'expédition et le transport des marchandises avec des emballages spéciaux demandés par le client et acceptés par ARCH, SA

## 5. Paiements

5.1 Le paiement des factures et régi par les « conditions générales de paiement » de ARCH, SA en vigueur à la date d'expédition.

5.2 Si le client subit un retard de paiement, ARCH, SA se réserve le droit de suspendre la commande en cours ou les commandes reçues entretemps

5.3 Dans le cas ou ARCH, SA prendrait connaissances de faits et circonstances qui pourraient engendrer le non-respect des obligations du client, se réserve le droit de suspendre la production et livraison des commandes en cours, sauf dans le cas ou le client présente des garanties qu'il pourra honoré ses obligations de paiement dans les délais accordés avec ARCH, SA

## 6. Garantie des produits céramiques

6.1 ARCH, SA offre une garantie de 20 ans sur tout les articles céramiques sanitaires conçu et produits par ARCH, SA à compté de la date de vente.

6.2 Les produits qui, durant cette période, présenteraient quelconque problème technique ou qualitatif seront échangés sans aucun coût pour le client.

6...3 Pour que la garantie soit activée, il est nécessaire que les défauts soient communiqués par écrit au service commercial de ARCH, SA et

accompagnés des respectifs documents prouvant la vente et livraison de la part de ARCH, SA pour ainsi prouvé l'origine et la date de livraison.

6.4 L'acceptation de la réclamation sera conditionnée par la validation de nos services techniques, pour la détection des causes couvertes par la garantie ici décrite, tel que usage inadéquat, défaut lors de l'installation ou manutention, casse lors du transport, manipulations, réparations ou modifications effectuées par un tiers, sans notre consentement par écrit.

6.5 La garantie sur les produits céramiques conçu et produits par nos soins, exclus toute responsabilité provenant d'éventuelles incompatibilités techniques des installations du client, mauvaises conditions d'installation, ainsi que quelconque mauvaise condition de stockage ou manutention et nous n'accepterons aucune réclamation pour les dépenses engendrées par ces points.

6.6 Le matériel réclamé sera fourni par ARCH, SA le plus rapidement possible dans la mesure de la disponibilité du matériel identique.

### **7. Garantie sur les composant non céramiques**

7.1 ARCH, SA garanti 2 ans, à partir de la date d'achat, les produits non céramiques commercialisés et décrits ci-dessous :

- Composants des mécanismes de décharge : Vannes, joints, réservoirs
- Composants des WC : Systèmes de fixation, abattants, tuyaux d'évacuation
- Composants des bidets : Robinets, vannes, abattants et fixations
- Composants des lavabos : Robinets, vannes et fixations

7.2 Pour que la présente garantie soit valide, les équipements devront être installés en accord avec nos instructions techniques

7.3 La présente garantie ne couvre pas les défauts dus à une mauvaise utilisation, une usure prématurée pour cause de mauvais utilisation, configuration ou fonctionnalité, modifications réalisés par un tiers.

### **8. Réclamations**

8.1 Toutes les réclamations en relation avec la livraison de la marchandise devront être effectuées par écrit auprès de notre service commercial dans un délai de 5 jours ouvrés à partir de la date de livraison.

8.2 Toutes les réclamations au sujet des tarifs ou remises pratiqués sur la facture devront être effectuées par écrit auprès de notre service commercial dans un délai de 15 jours après la date de réception de cette facture

8.3 Toutes les réclamations techniques ou de qualités des nos produits et marchandises devront être réalisées par écrit auprès de notre service commercial, avec le descriptif du problème, pièces et quantitatif des articles concernés. Le client devra garantir le maintien de ces articles jusqu'à la récupération de ces derniers par ARCH, SA, sans coût pour le client, après bonne acceptation de la réclamation par ARCH, SA

8.4 ARCH, SA agira de façon a assuré une réponse en temps utile à la réclamation du client, dont le temps de résolution sera conditionné par l'analyse des causes et le nécessaire éclaircissement des responsabilités.

### **9. Retour**

9.1 ARCH, SA n'acceptera aucun retour sans antérieure validation par écrit du service commercial

9.2 ARCH, SA n'acceptera aucun Retour d'articles sanitaires, modèles

et coloris, que ne font pas, à la date du retour, partie de la gamme commercialisée.

9.3 Marchandises et composants ne faisant pas parti du catalogue commercialisé à la date du retour ou avec une date de vente supérieure \*a la garantie commerciale.

### **10. Litiges**

10.1 Le tribunal compétent pour intervenir dans quelconque litige émergeant des transactions commerciales régies par les présentes « conditions générales de vente » sera le Tribunal de Vila Nova de Gaia.

10.2 EN accord avec la loi 144/2015 du 8 septembre, en cas de litige le client peut recourir au « Centre d'Information de Consommation et Arbitrage » de Porto pour une résolution alternative de litiges de consommation

### **CONDITIONS GÉNÉRALES DE PAIEMENT**

1. Les livraisons à de nouveaux clients devront être payées par chèque ou liquide lors de la livraison. L'ouverture de droit au crédit ne pourra être concédée qu'après approbation de la Direction Financière et Direction Commercial de ARCH, SA

2. Une fois le crédit accordé avec plafonds défini, toutes les factures devront être payées dans un délai maximum de 60 jours après date d'émission.

3. En début de chaque mois sera éditée une liste de factures du mois antérieur

4. Seront accordés des escomptes en accord avec les conditions définies pour tout paiement anticipé

5. ARCH, SA se réserve le droit de débité des intérêts compensatoires dans le cas de non-respect des conditions de paiements. En aucun cas ne sera acceptée, pour justifier le retard de paiement des facture en cours, l'existence d'une situation litigieuse sur un autre produit ou livraison.

6. Il y aura suspension de fourniture dans les cas suivants :

7. Paiement de commande avec chèque sans provision
8. Des factures non réglées avec des dates de paiement dépassées
9. Plafond de crédit dépassé

10. A aucun client dont le crédit a été suspendu ne sera fournie la moindre commande, même si cette nouvelle commande est payée en anticipée

### **CONDITIONS GÉNÉRALES**

1. A tous les prix spécifiés sur le relevé tarifaire sera ajouter la TVA légale en vigueur

2. Les prix spécifiés sur le relevé tarifaire peuvent subir des modifications sans préavis

3. Les caractéristiques et dimensions des articles spécifiés sur le relevé tarifaire sont assujettis aux tolérances techniques règlementées dans les normes du secteur d'activité.

ARCH, SA se réserve le droit de retirer et modifier les références des articles et marchandises commercialisés et spécifiés dans le relevé Tarifaire..



# Valadares

ORIGINAL BATHROOMS

SINCE 1921

**SEDE / FÁBRICA** | HEADQUARTERS/ FACTORY

Av. António Coelho Moreira

4405-528 Vila Nova de Gaia

Portugal

+351 223 238 038

comercial@archvaladares.com

[www.archvaladares.com](http://www.archvaladares.com)

[www.arch.pt](http://www.arch.pt)